



Stanford Energy Systems Innovations (SESI)

STANFORD UNIVERSITY

Colin Moyer, PE



November 12, 2015

Agenda

- Background
- Why Heat Recovery is Possible
- Heat Recovery System Selection
- Plant Arrangement / Operation
- Campus Conversion
- New Electrical Substation
- Replacement Central Energy Facility
- Administrative Wing
- Results

Background

- 1987 Cogen plant nearing end of life
- Growing campus
- Economic efficiency and stability
- Environmental stewardship



Background

Campus Utility Services *Cogeneration Plant is 90% of the Greenhouse Gas*

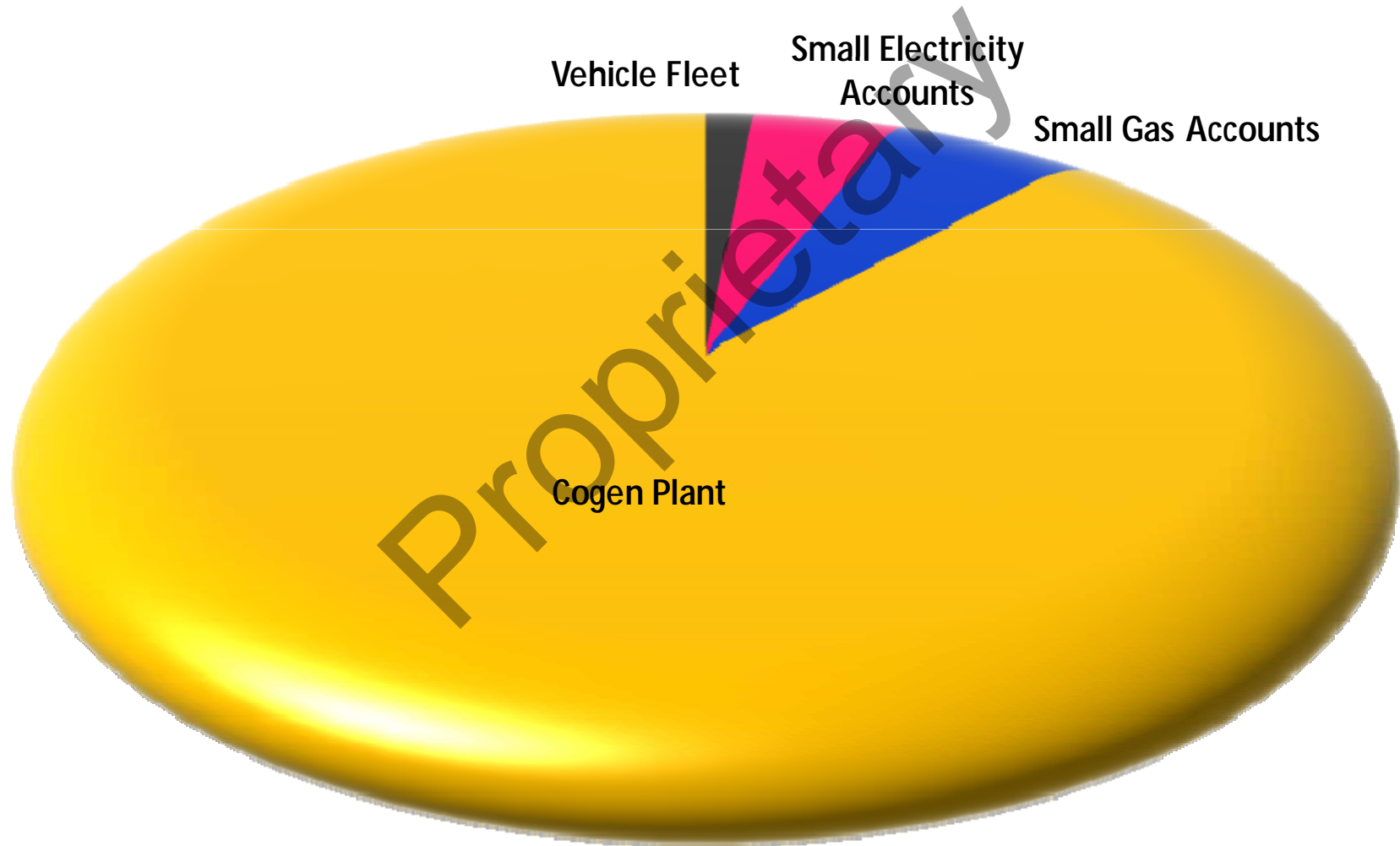

Why Heat Recovery is Possible



Waste Heat Was Discarded from Cogeneration Plant

Why Heat Recovery is Possible

- **We heat & cool buildings at the same time**
- **Cooling is just the collection of unwanted heat**

Could recover 65% of the heat now discharged from the cooling system to meet 80% of campus heating demands.

Summer

Heat Recovery Potential at Central Energy Facility
Sample Date 7/23/2008

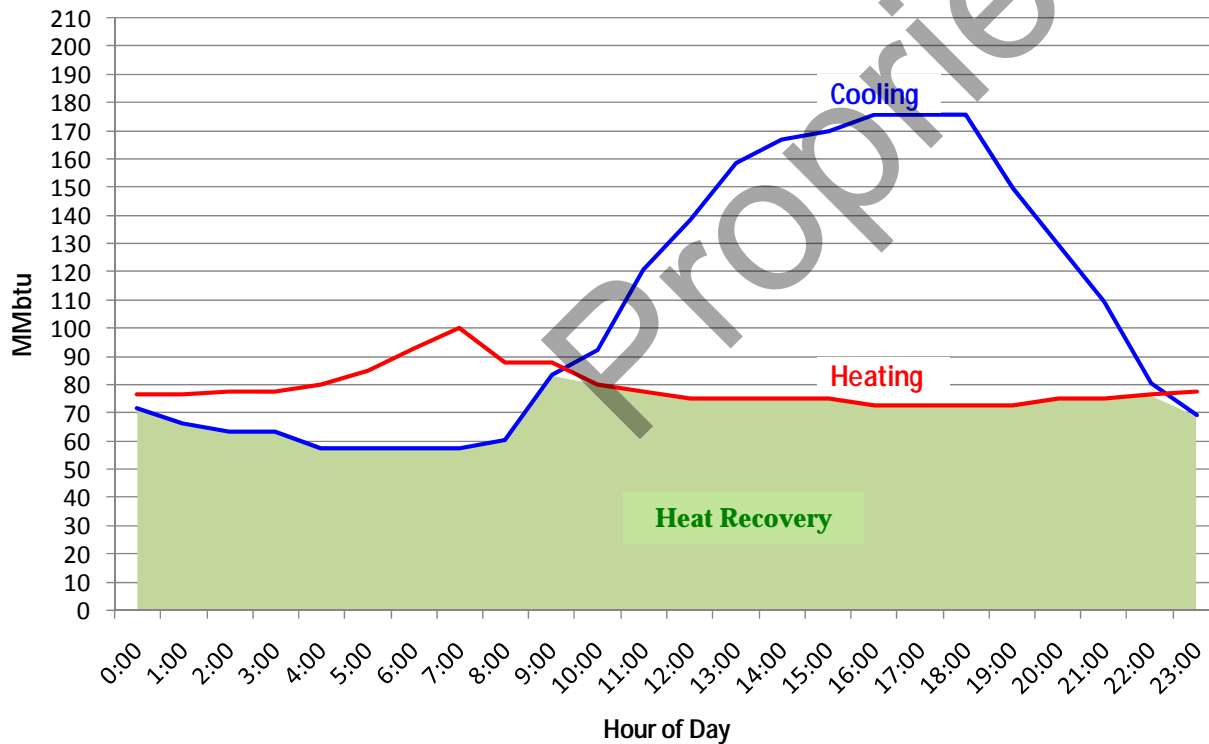

Heat Recovery Potential at Central Energy Facility
Sample Date 4/16/2008

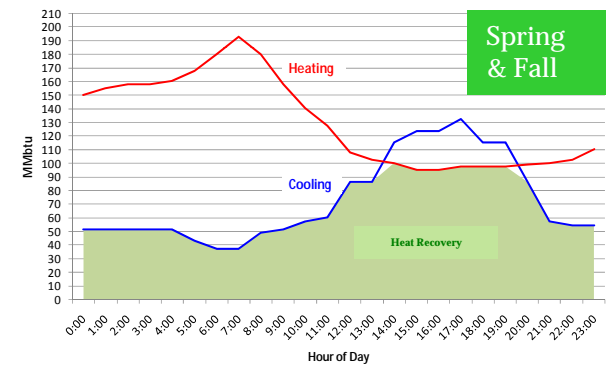

Spring & Fall

Heat Recovery Potential at Central Energy Facility
Sample Date 1/23/2008

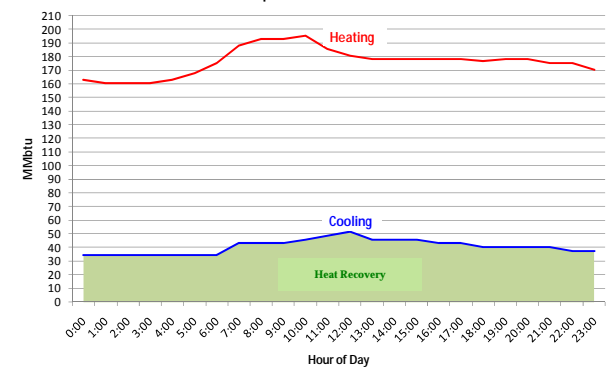

Winter

Why Heat Recovery is Possible

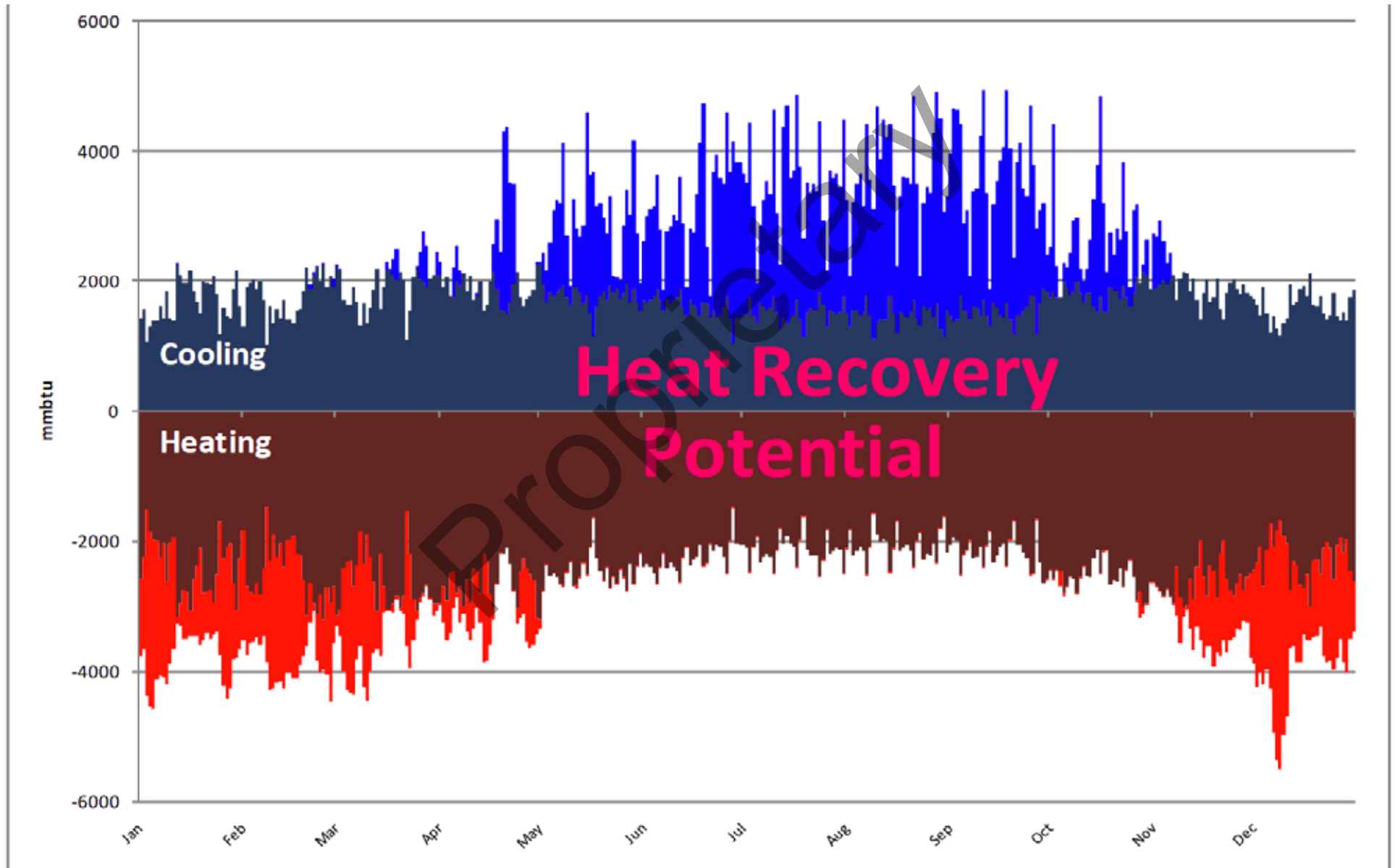

Why Heat Recovery is Possible

Energy can neither be created nor destroyed, but only changed from one form to another.

- First law of thermodynamics

- Why burn fossil fuel for heating if low grade thermal energy is readily available from existing cooling processes?
- Best application for new campus heat recovery system:
 - Mild climate with good heating and cooling overlap
 - Existing central heating & cooling system

Why Heat Recovery is Possible

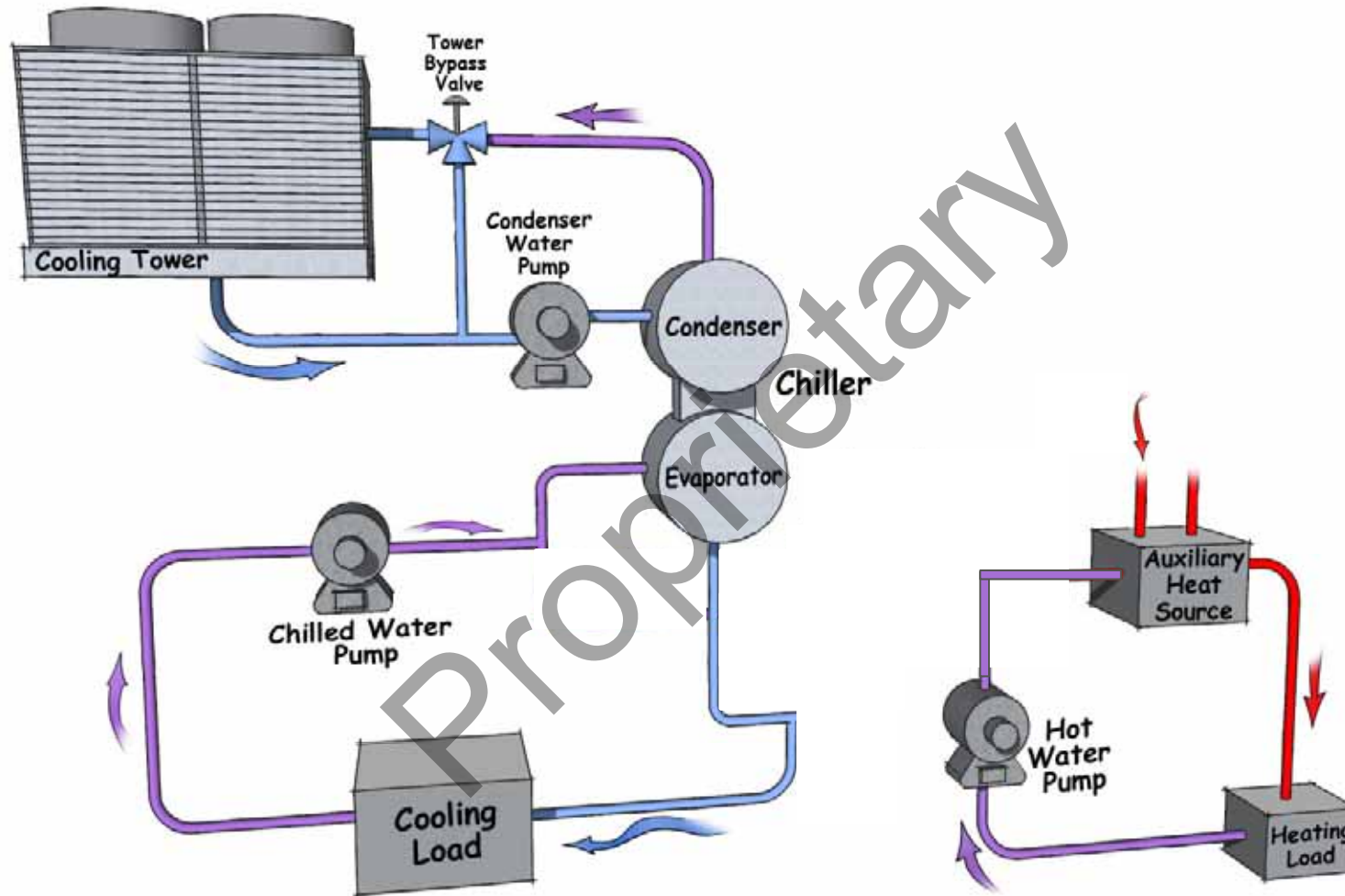

Why Heat Recovery is Possible

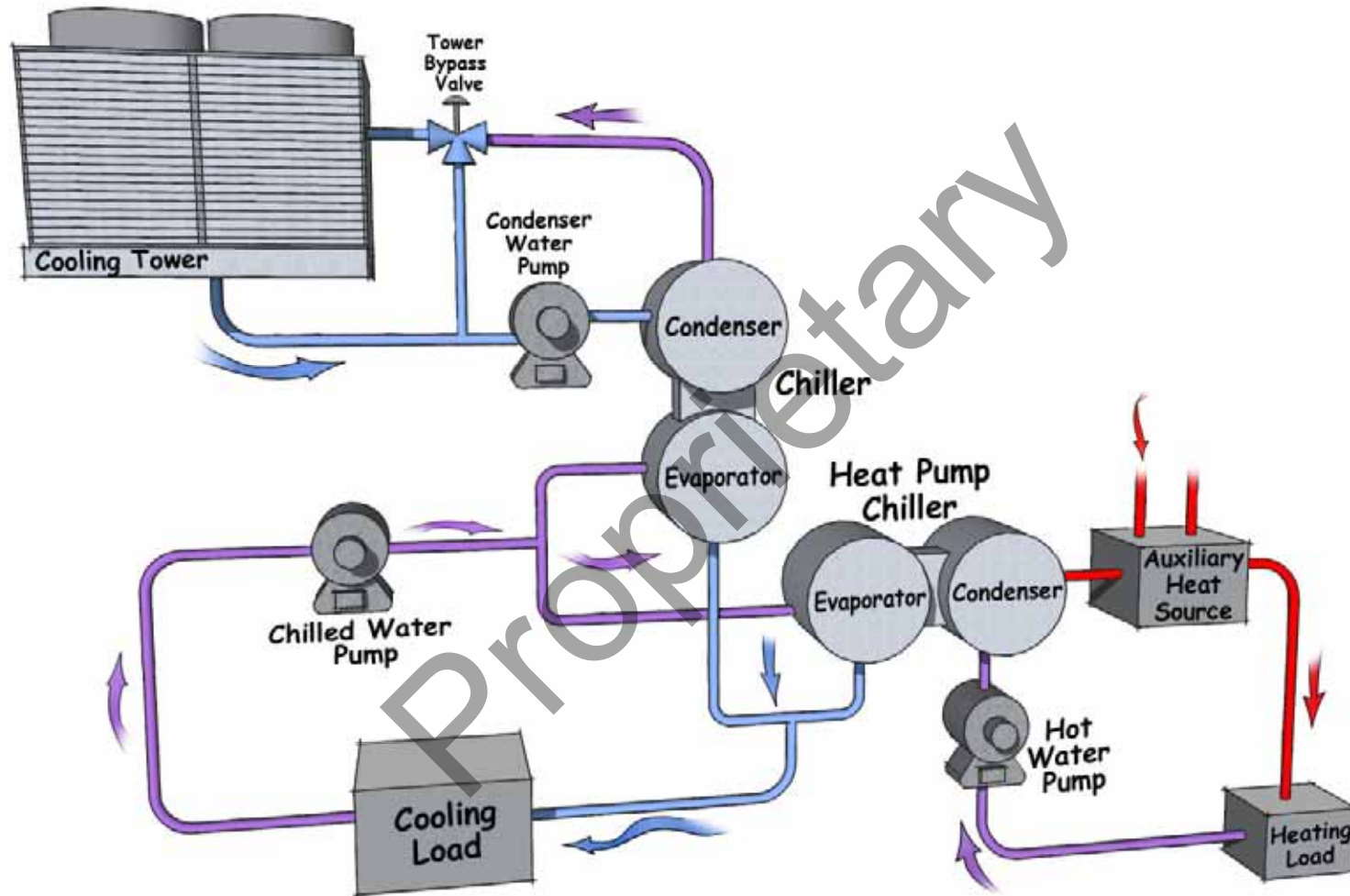

Why Heat Recovery is Possible

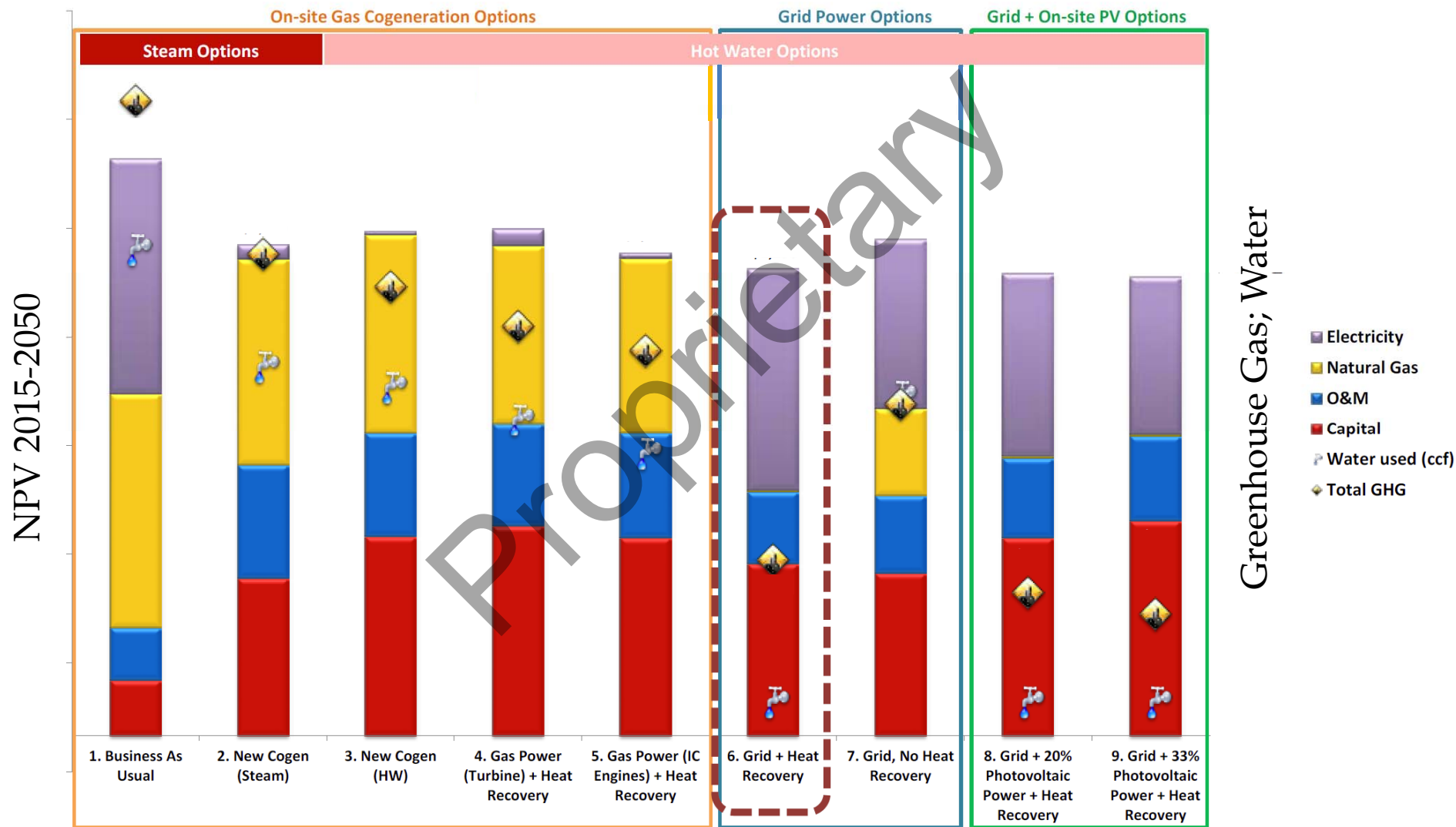

Heat Recovery System Selection

- Setting Supply Temperature
- Winter Test for Existing Building
- Vendor Interface
- Analysis of COP vs Supply Temp



Heat Recovery System Selection

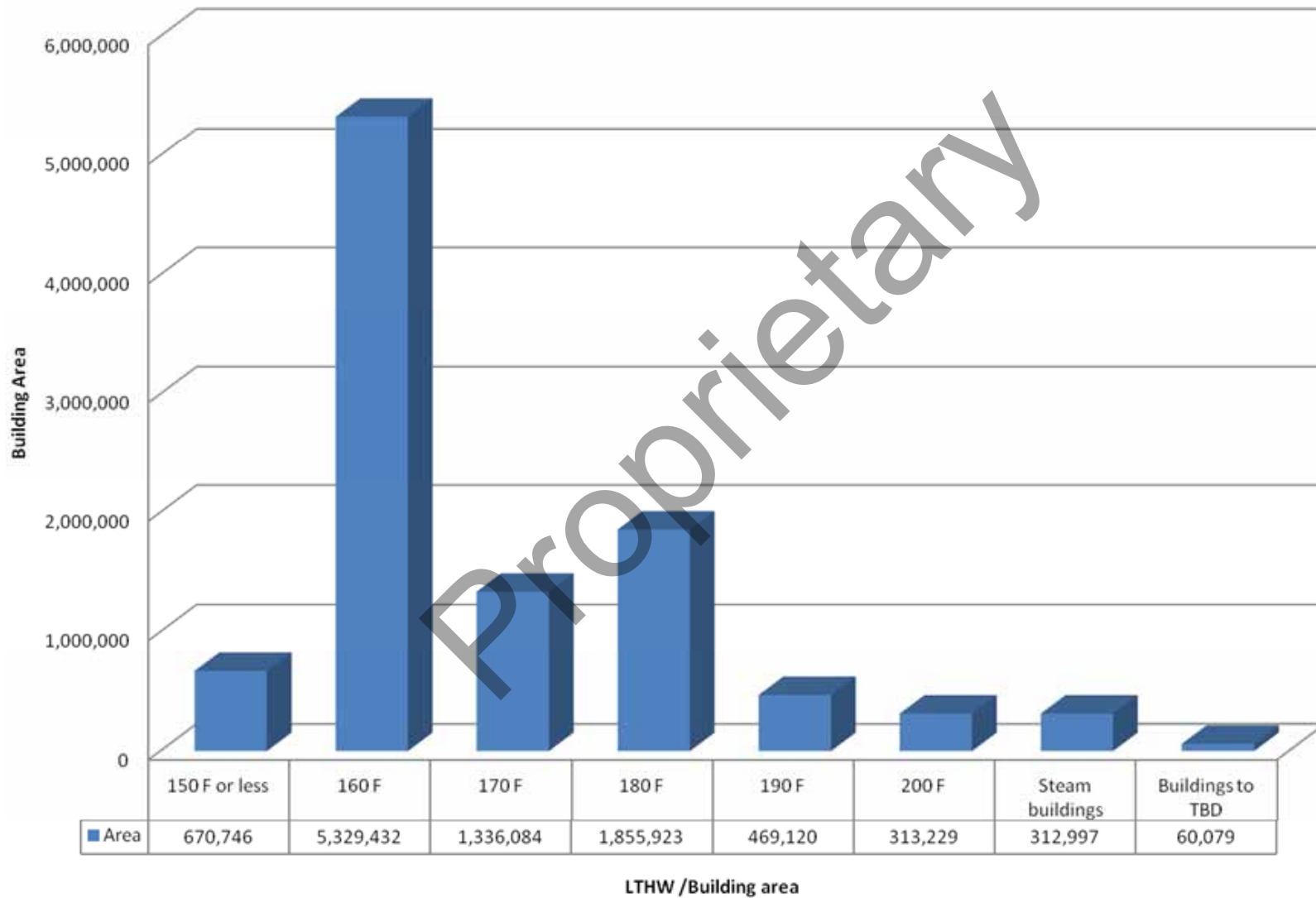

Heat Recovery System Selection

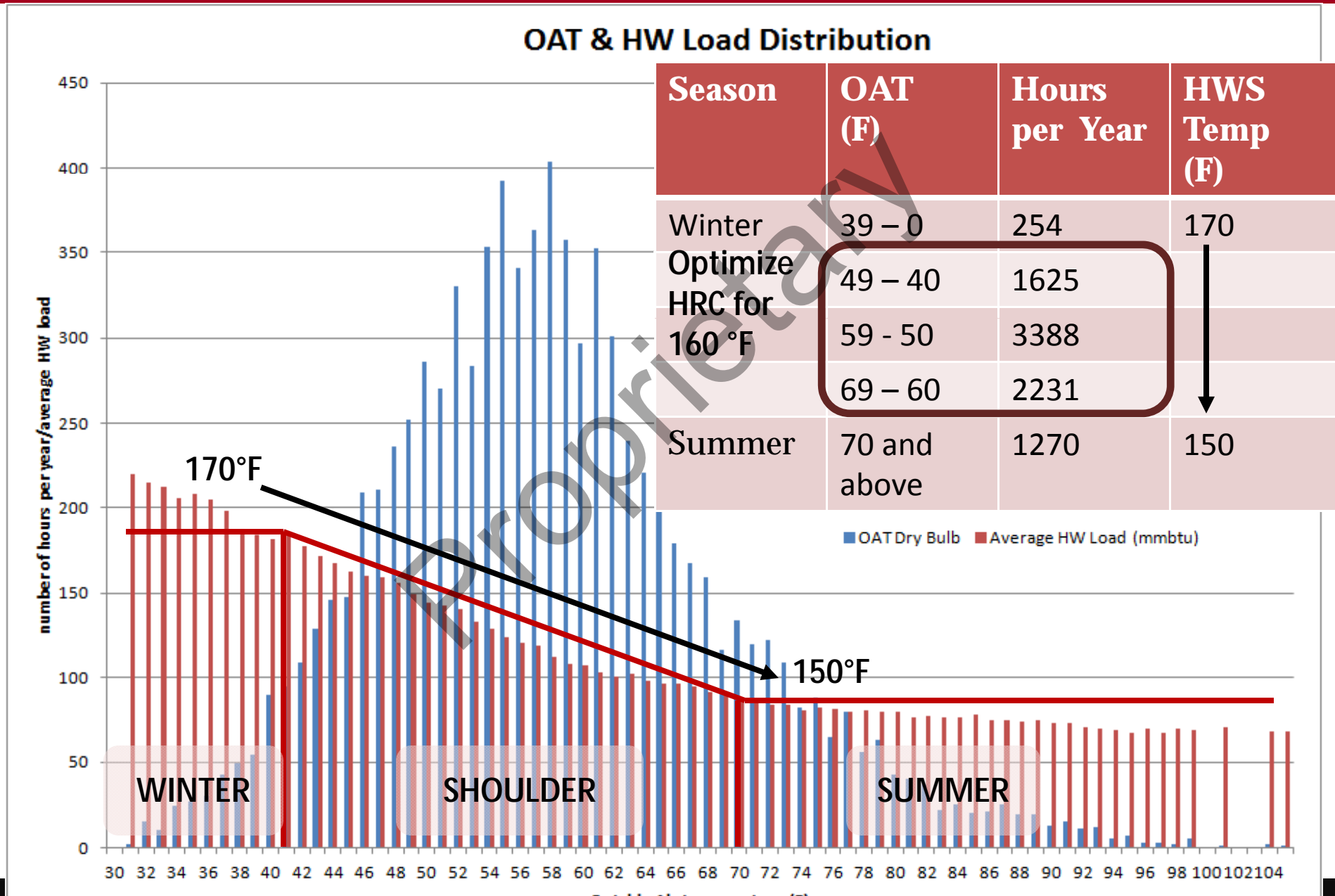

Heat Recovery System Selection



Heat Recovery System Selection

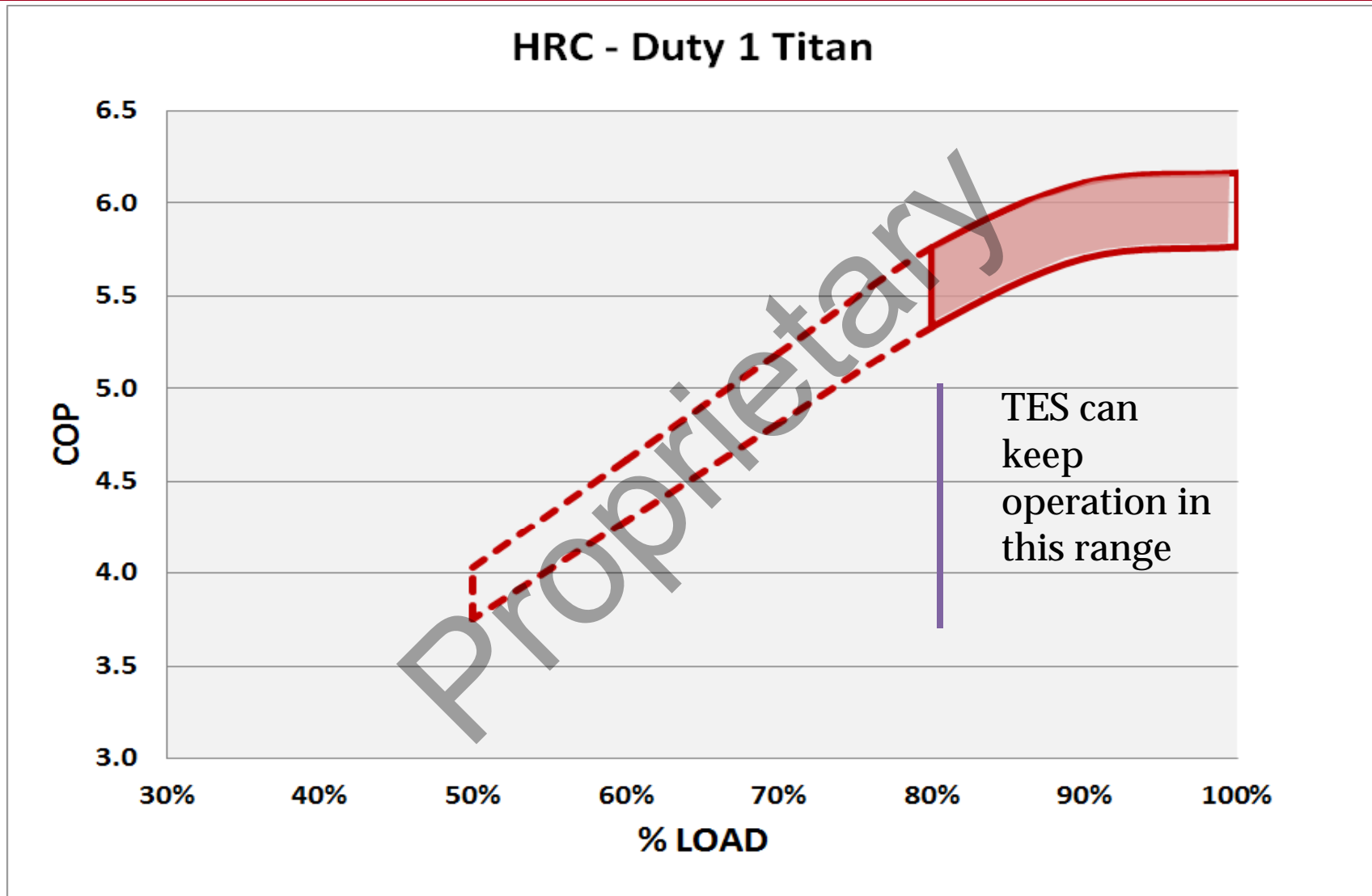

Plant Arrangement / Operation

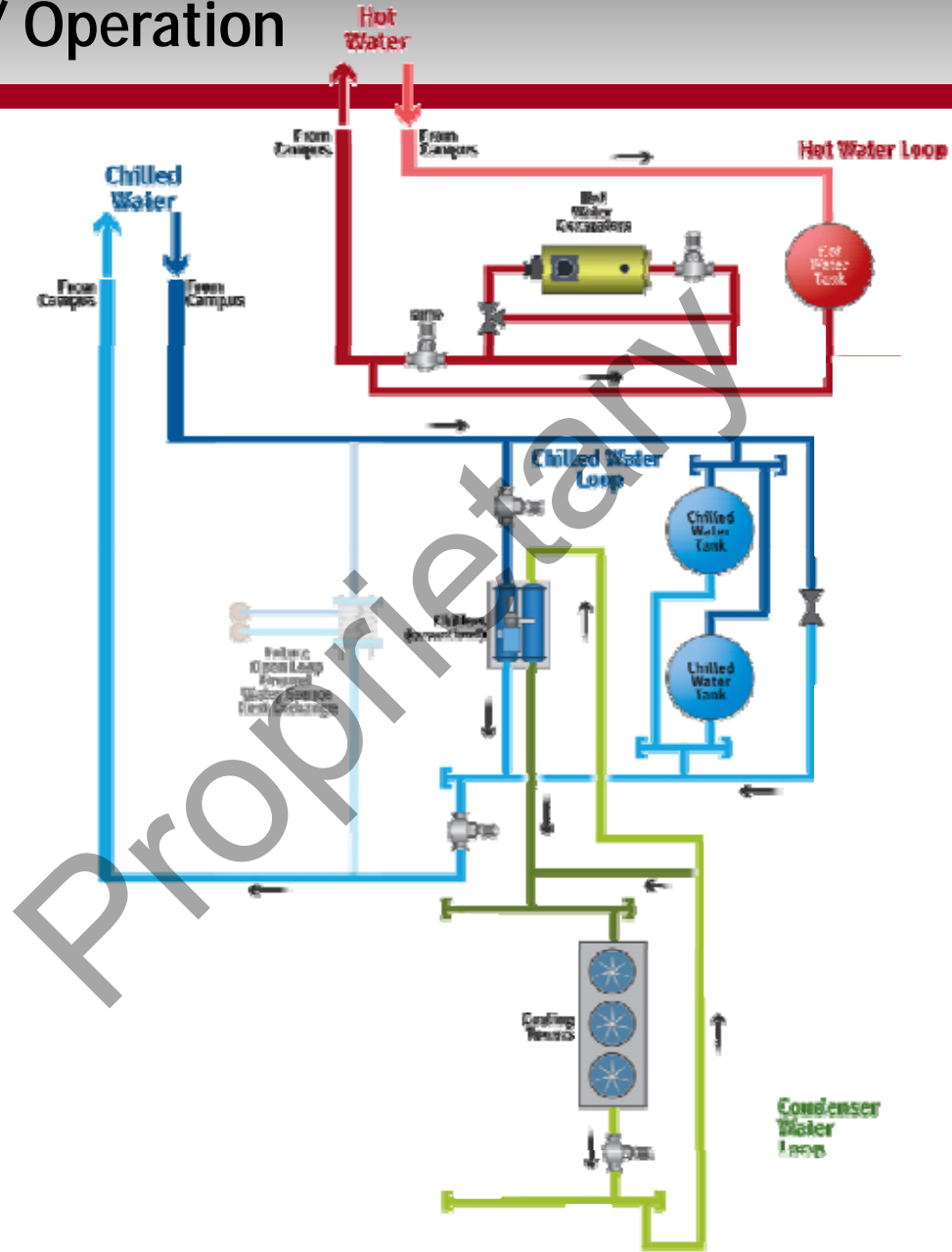

© 2015 Affiliated Engineers, Inc.

Plant Arrangement / Operation

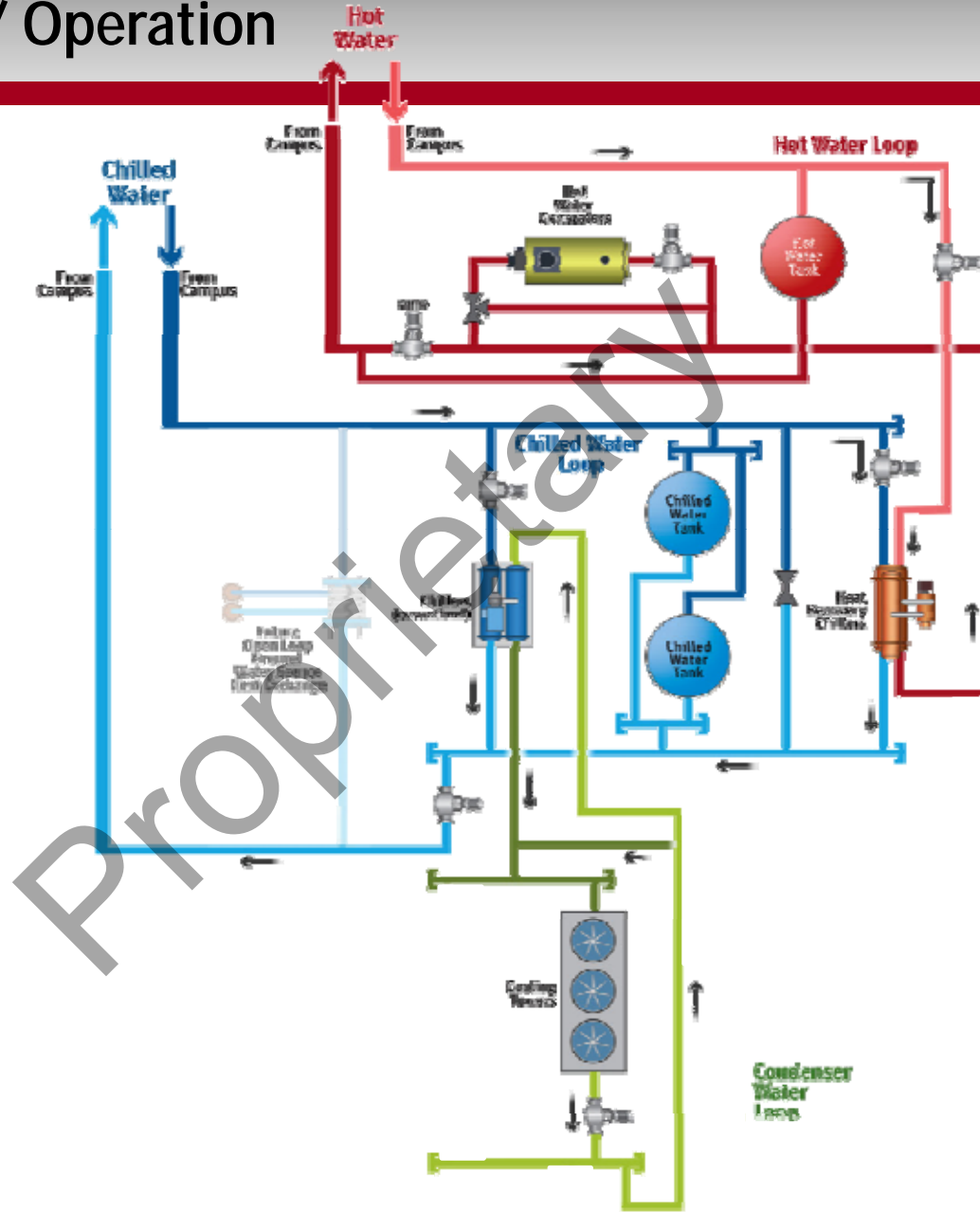

© 2015 Stanford Energy Systems Innovations, Inc.

Plant Arrangement / Operation

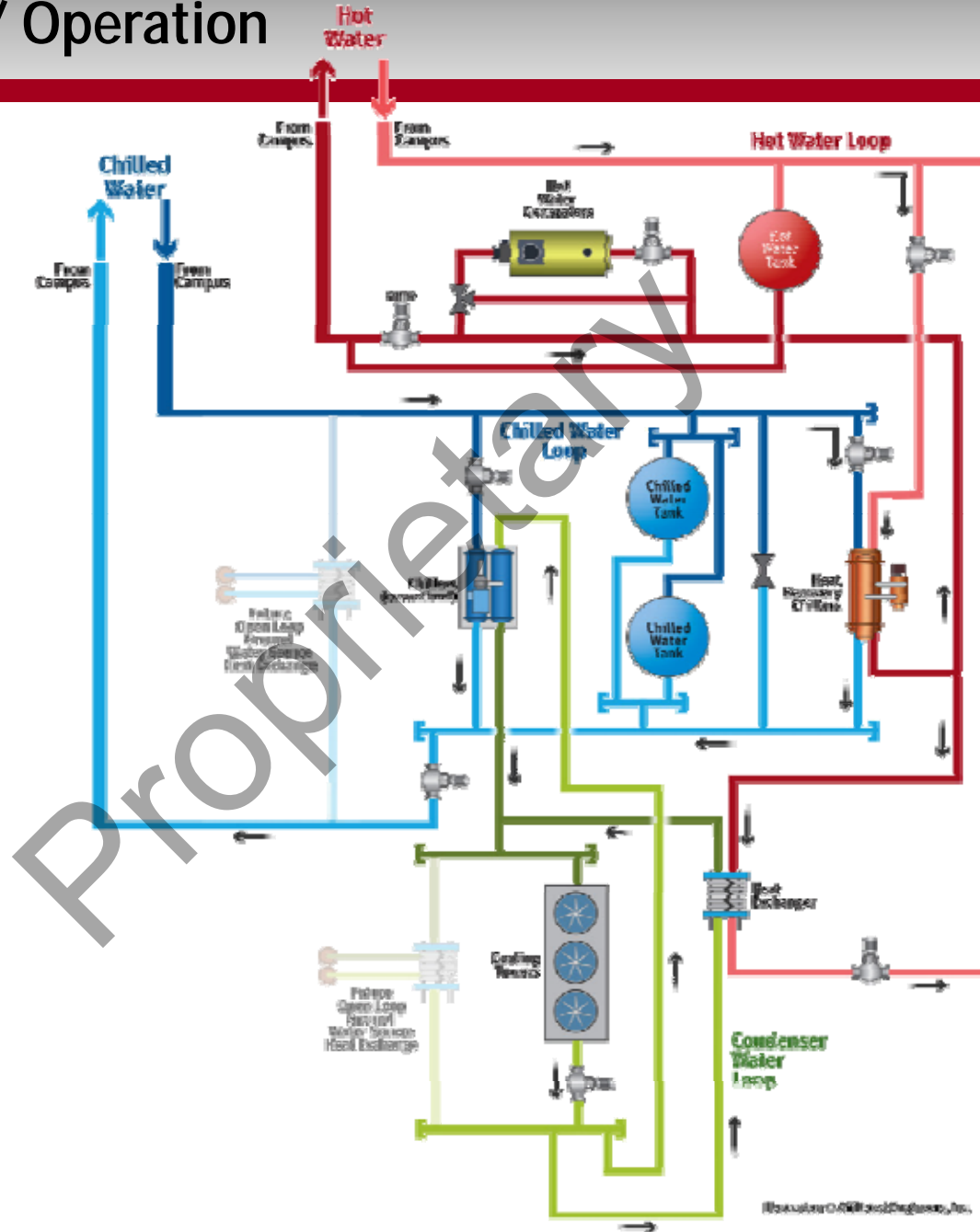

Plant Arrangement / Operation

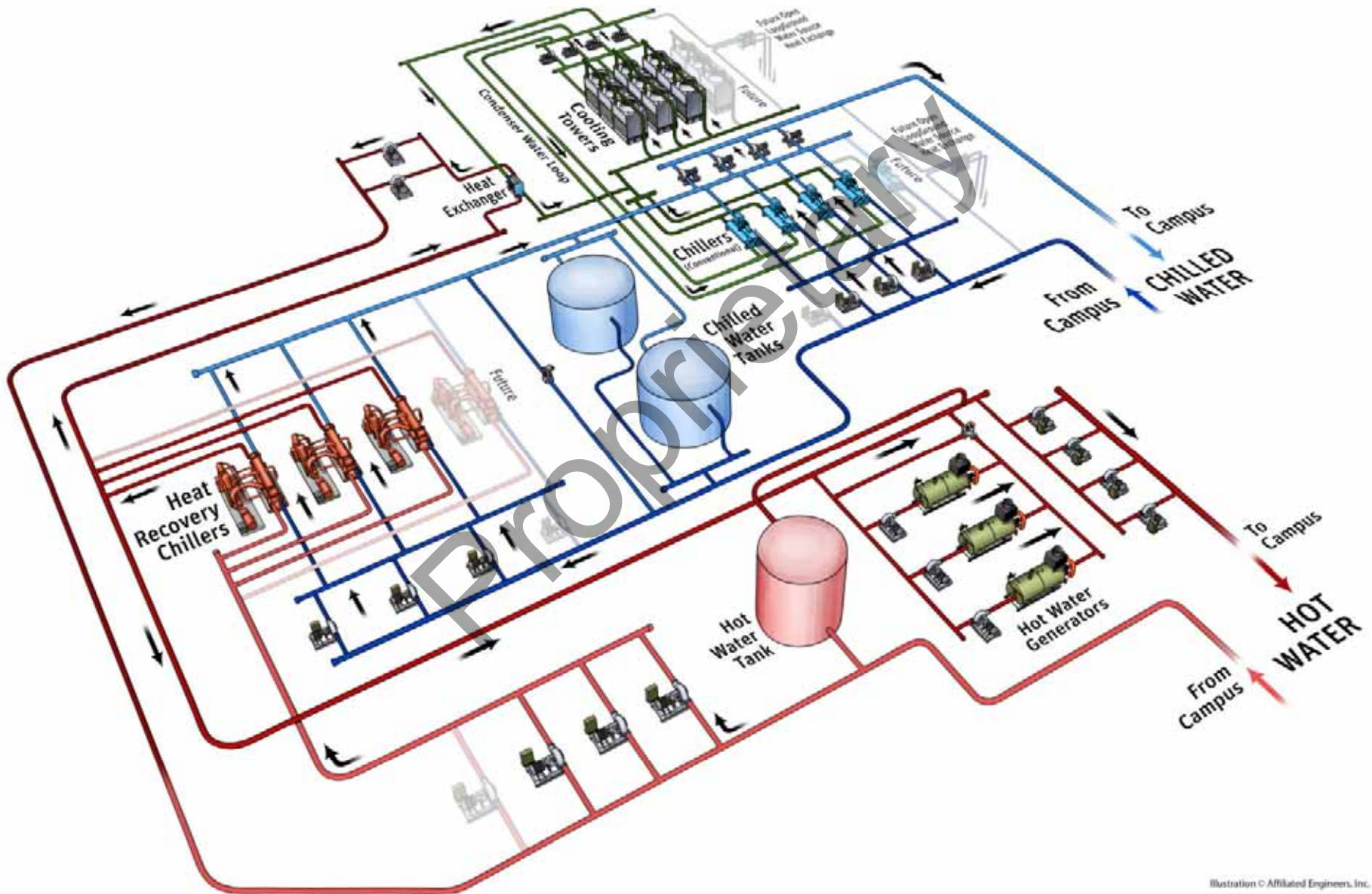

Illustration © Affiliated Engineers, Inc.

Plant Arrangement / Operation

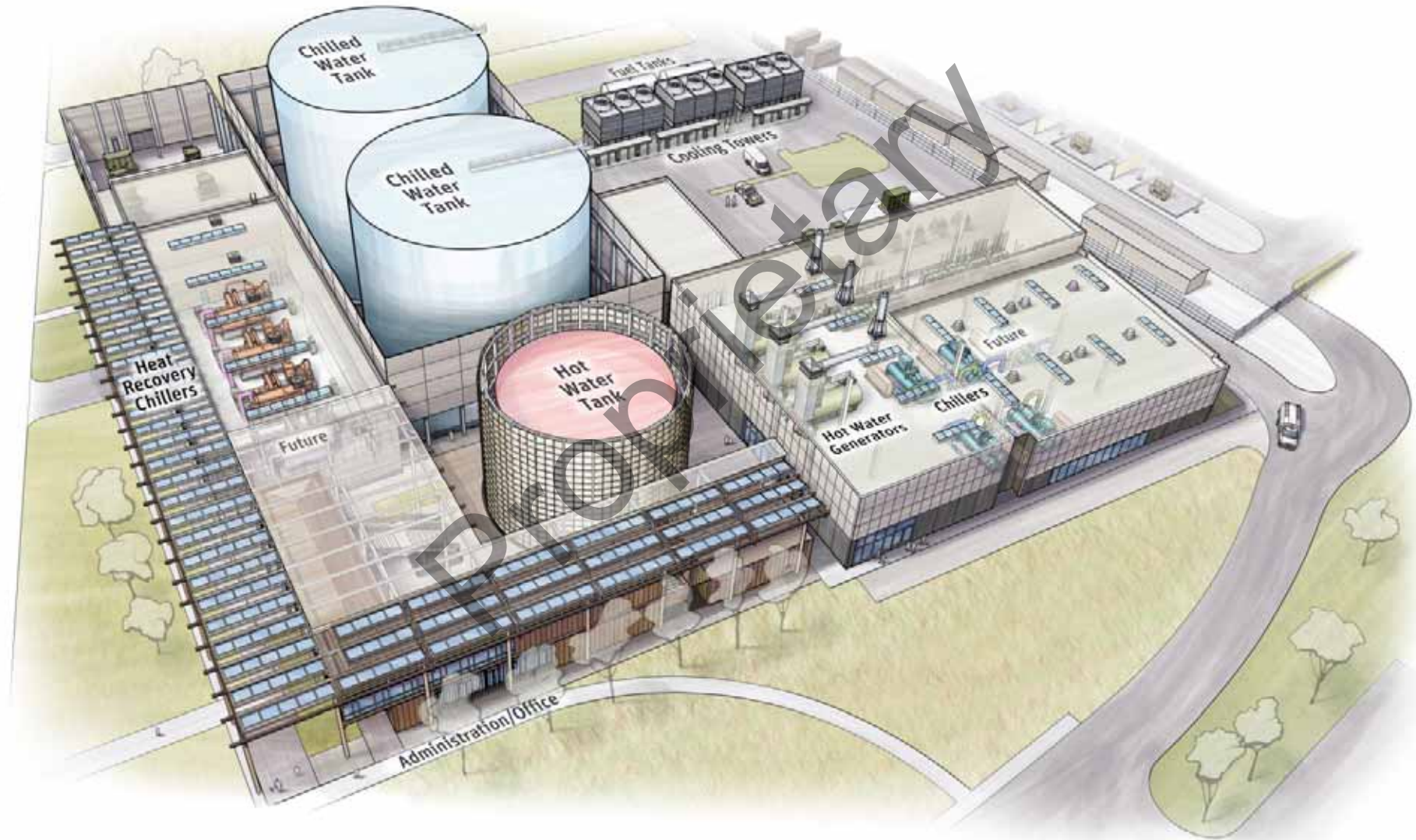

Illustration © Affiliated Engineers, Inc.

Plant Arrangement / Operation



Plant Arrangement / Operation

- 12,000 tons conventional chillers and cooling towers
- 7,500 tons and 120,000 MBH heat recovery chillers
- 180,000 MBH hot water generators
- 10,000,000 gallons chilled TES (90,000 ton-hours)
- 2,000,000 gallons hot TES (600,000 MBTU)

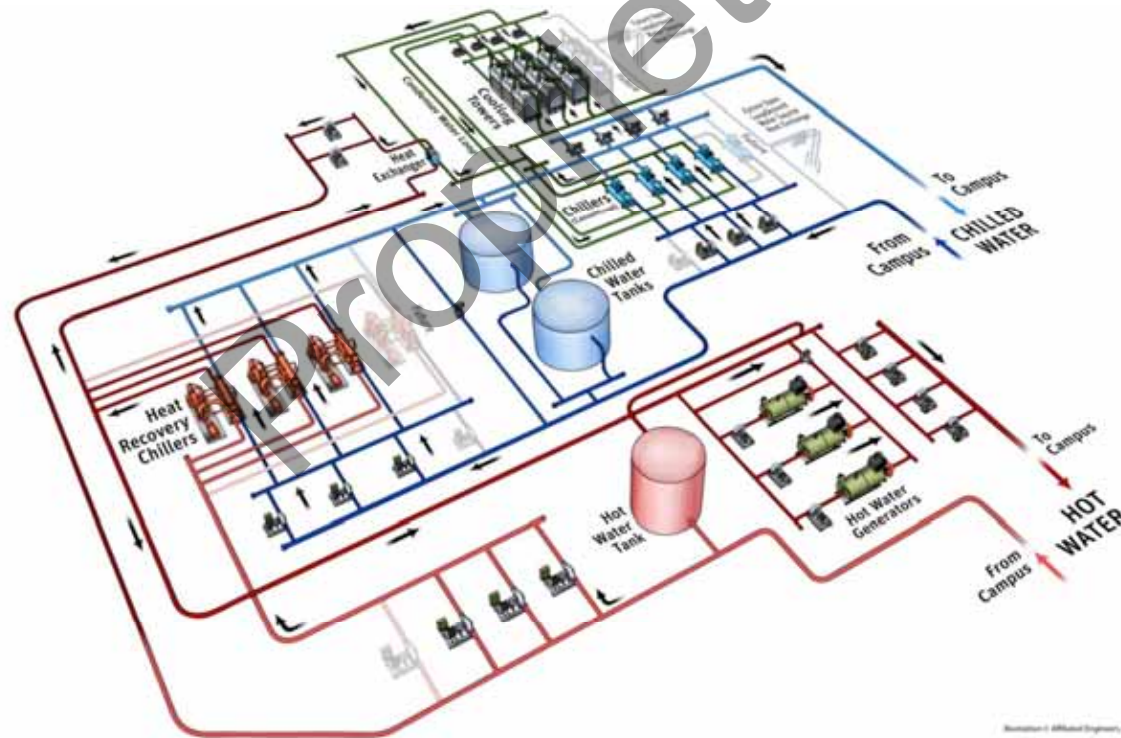

Plant Arrangement / Operation

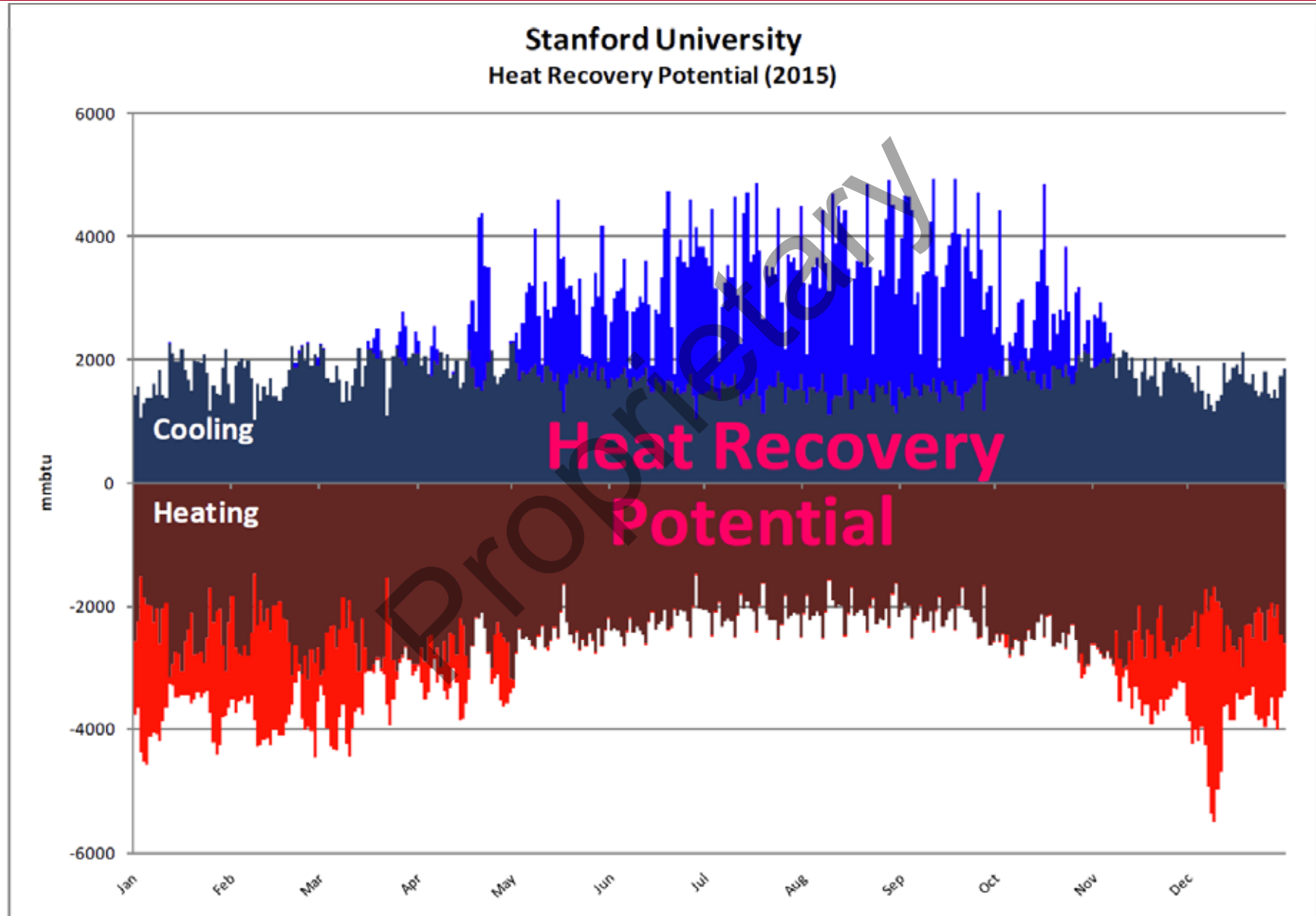

Plant Arrangement / Operation

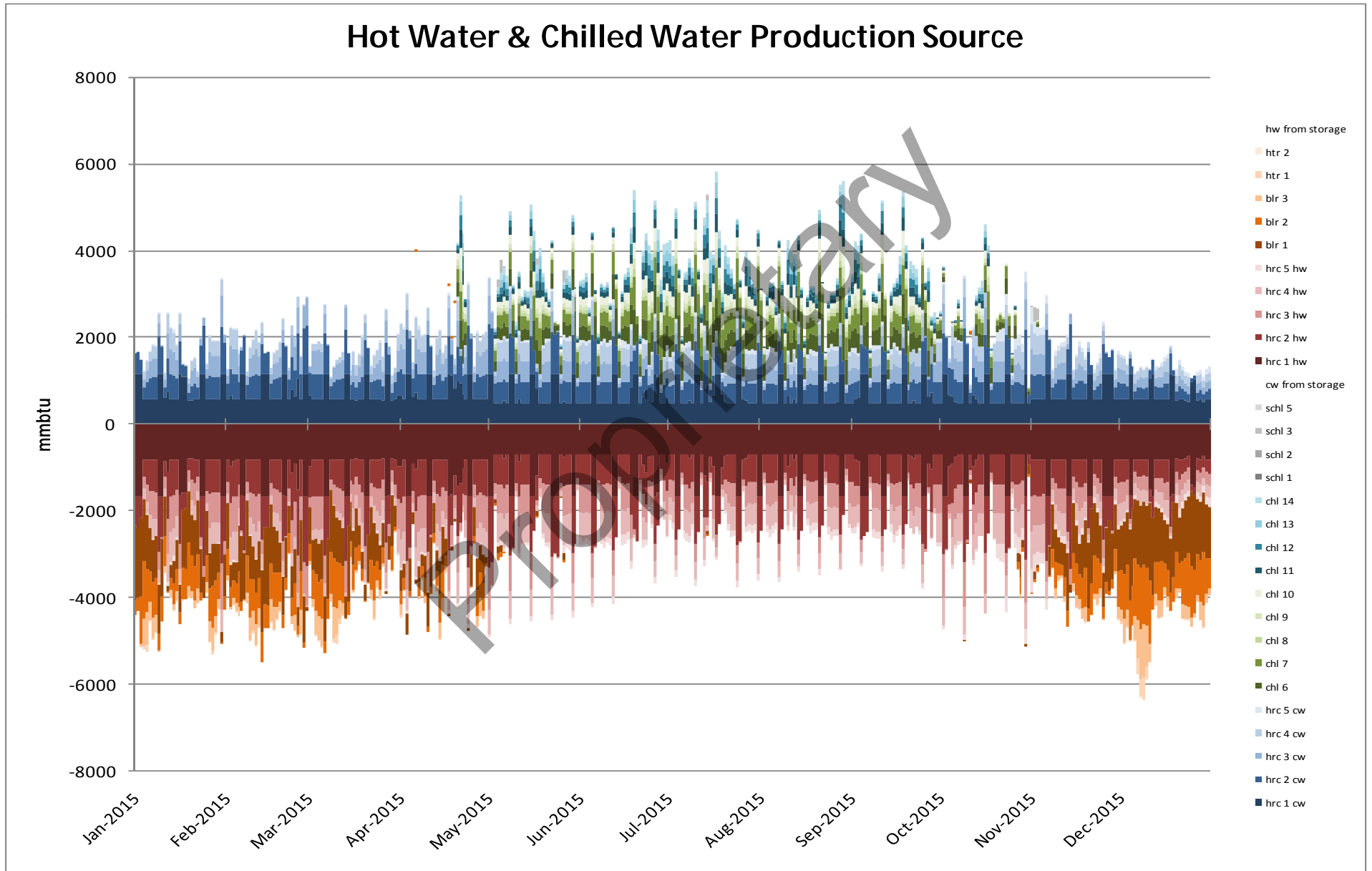

Plant Arrangement / Operation

CEP
Dispatch

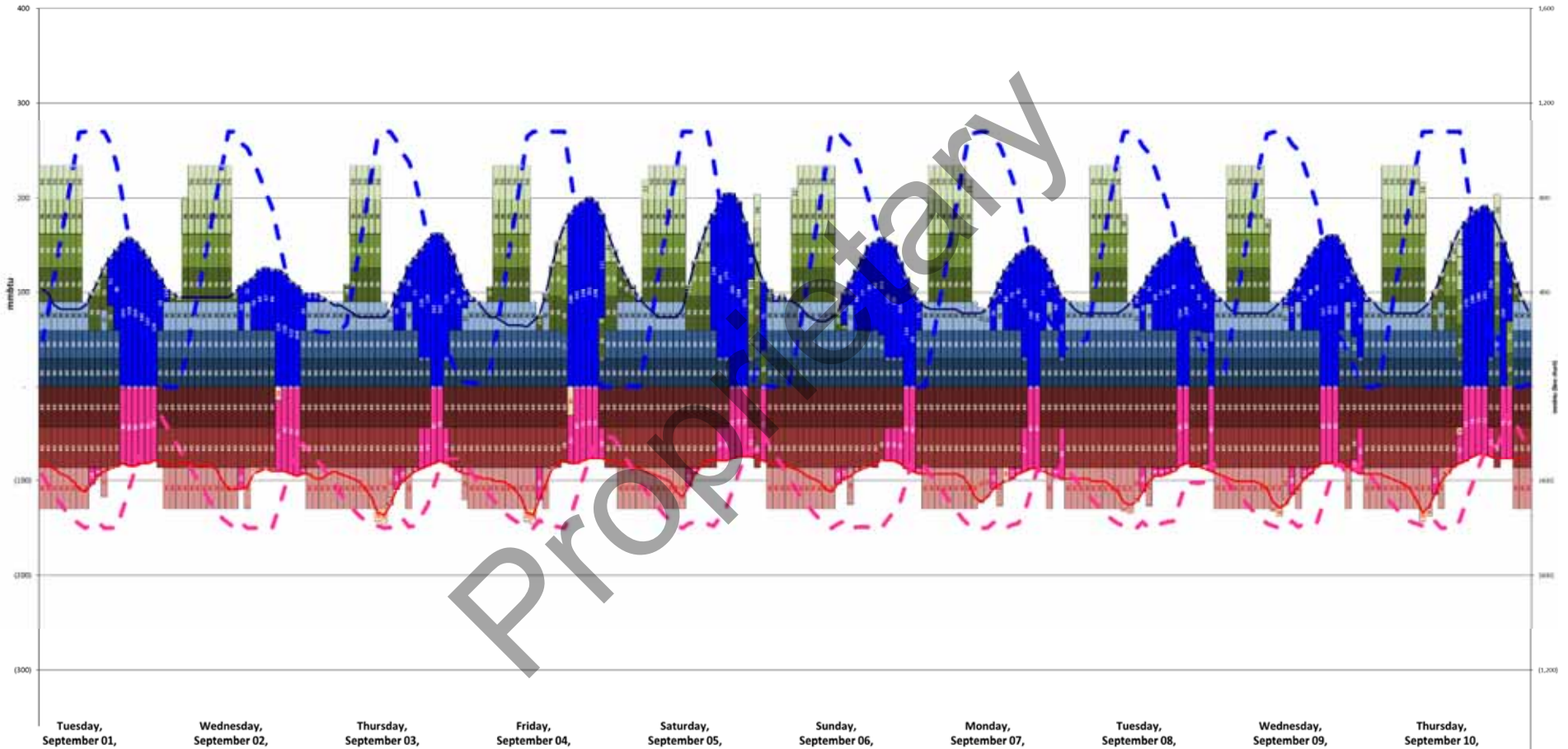

Plant Arrangement / Operation

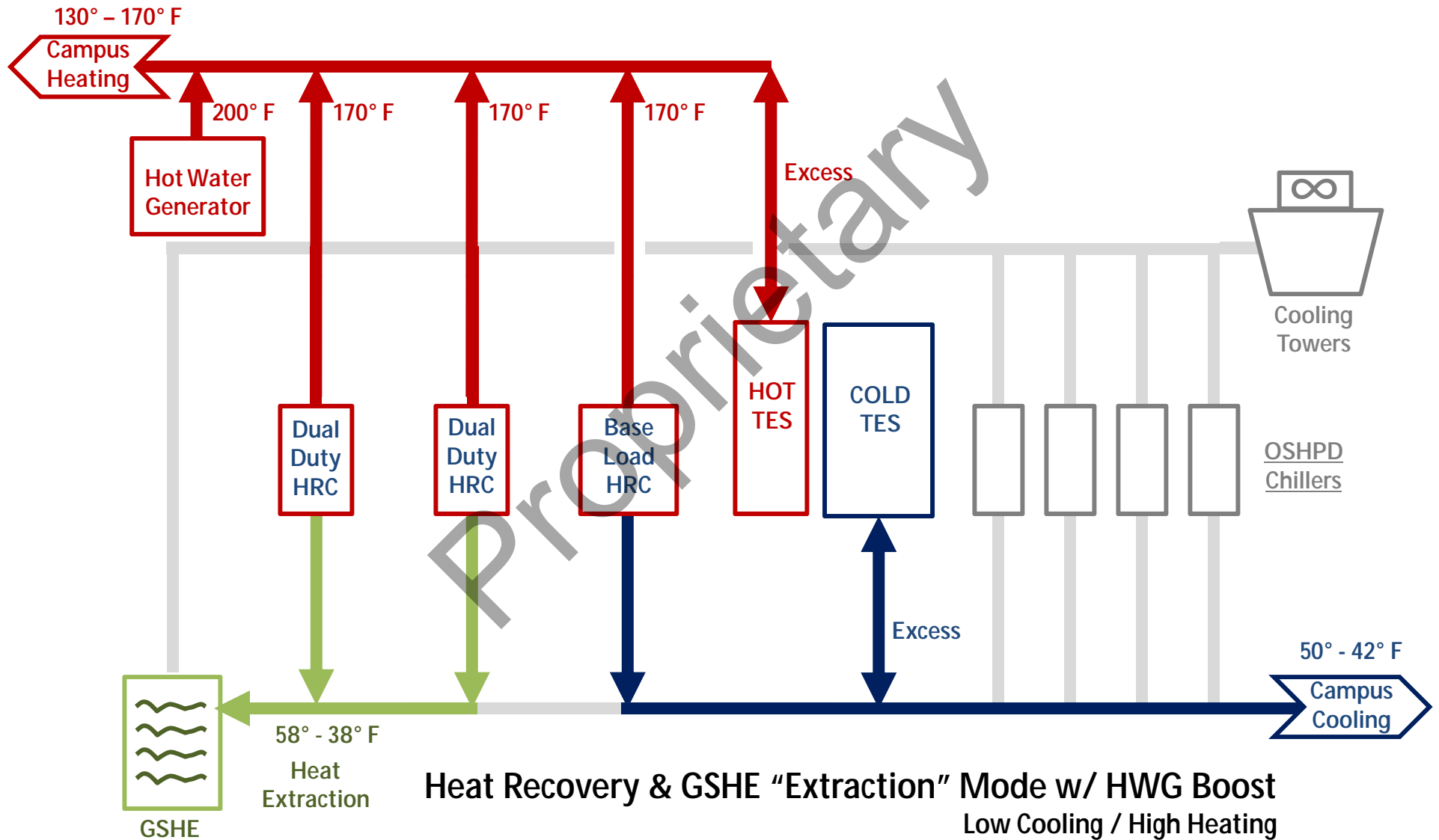

Plant Arrangement / Operation

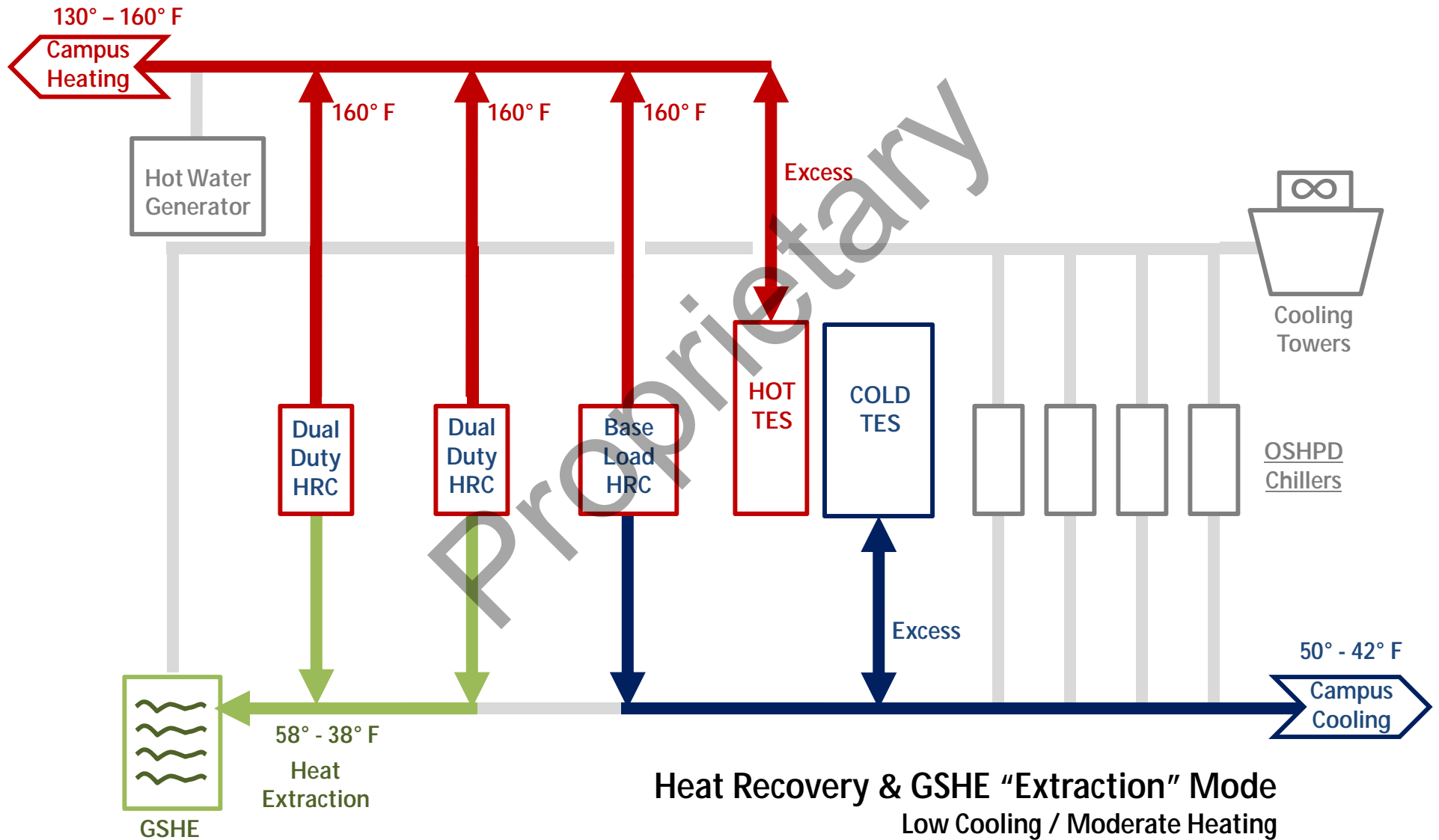

Plant Arrangement / Operation

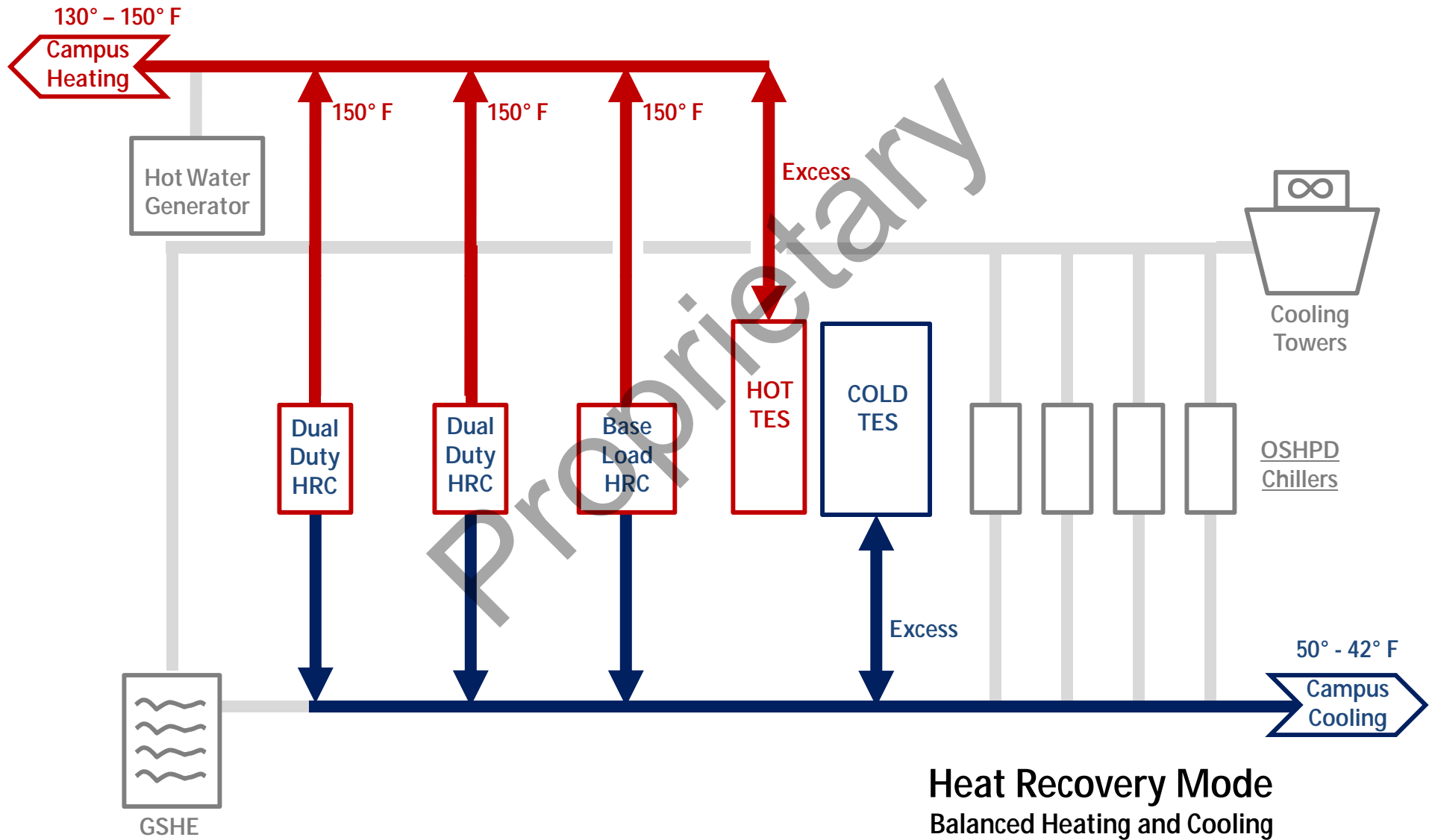

Plant Arrangement / Operation

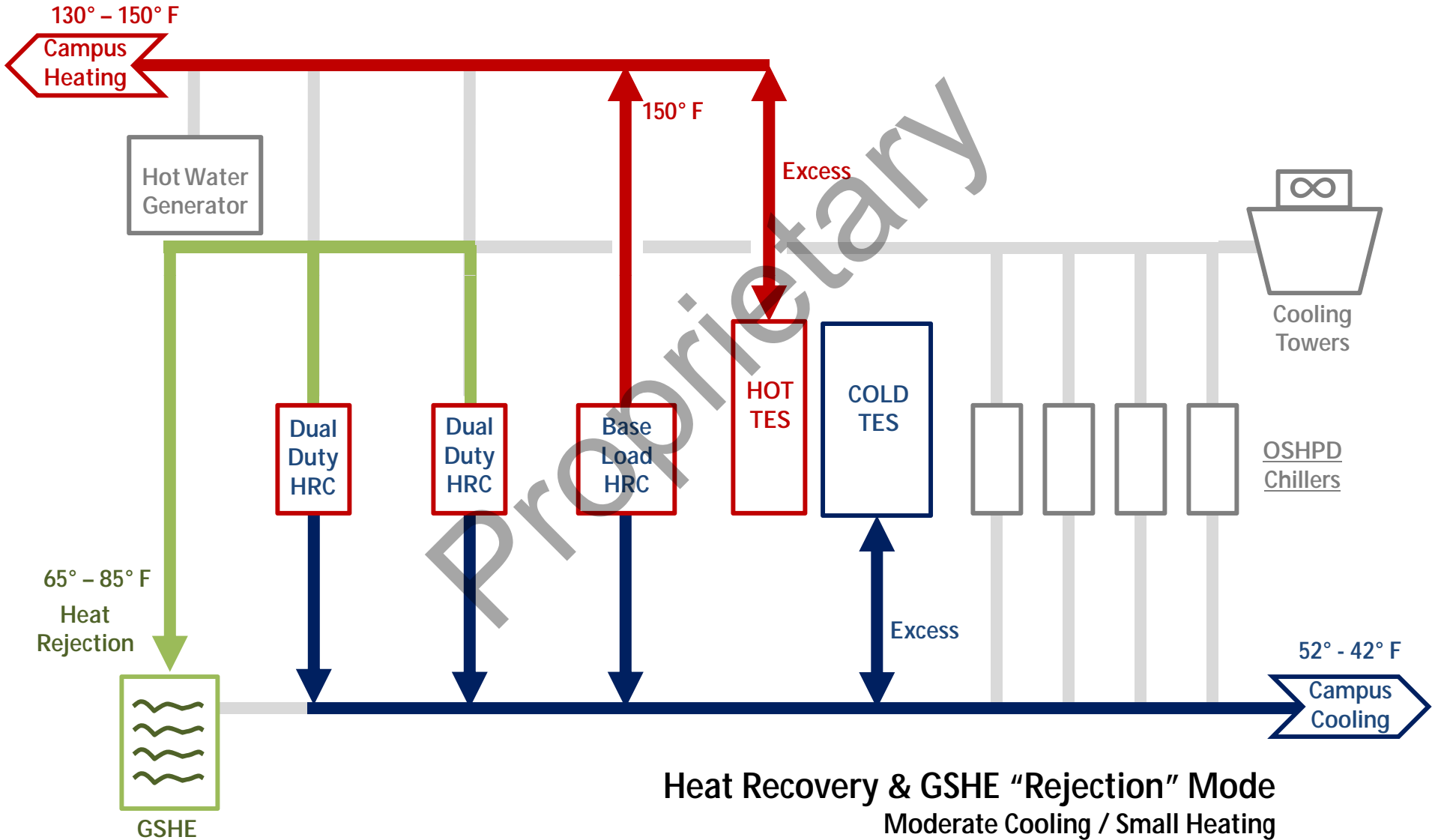

Plant Arrangement / Operation

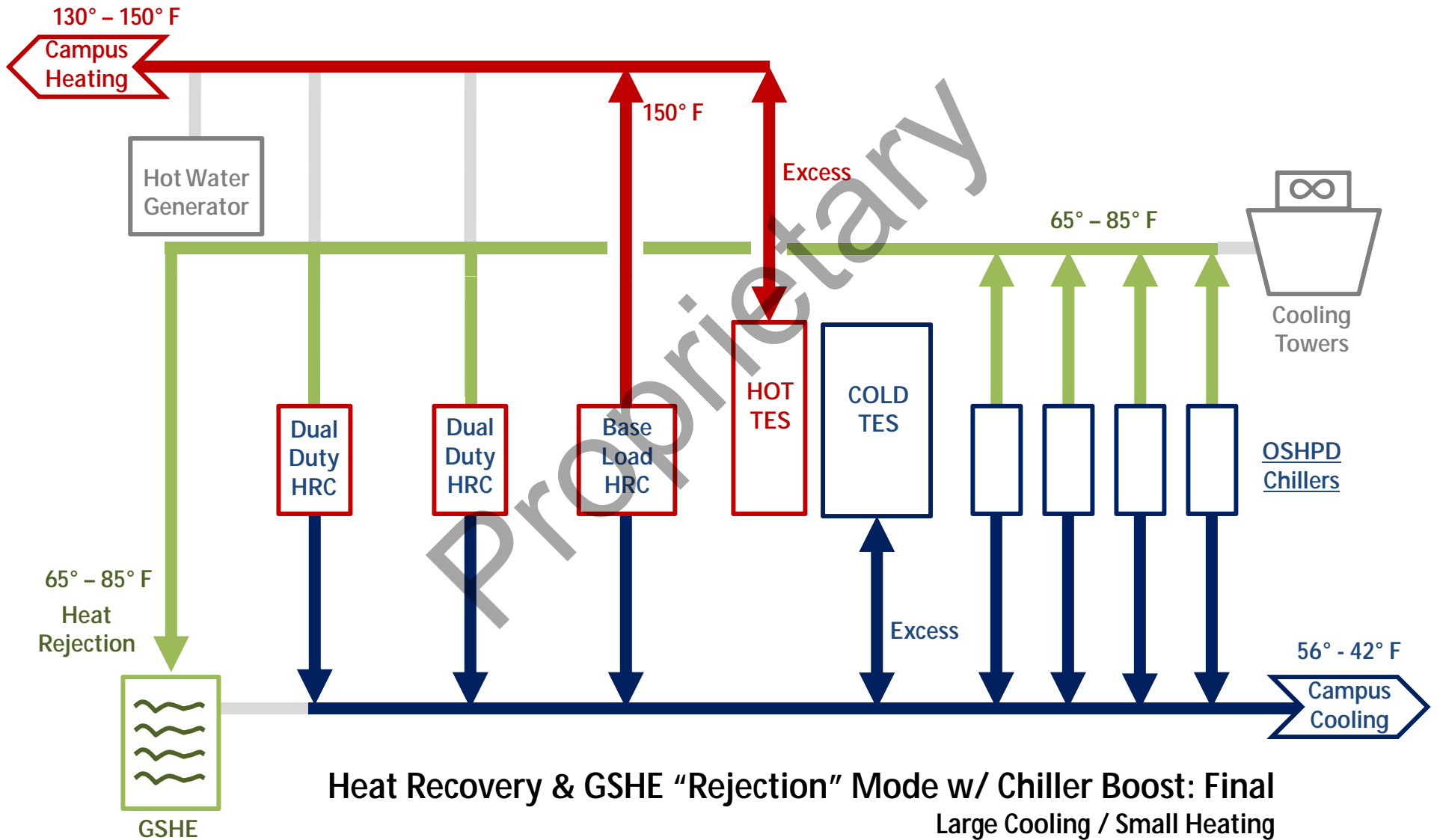

Plant Arrangement / Operation

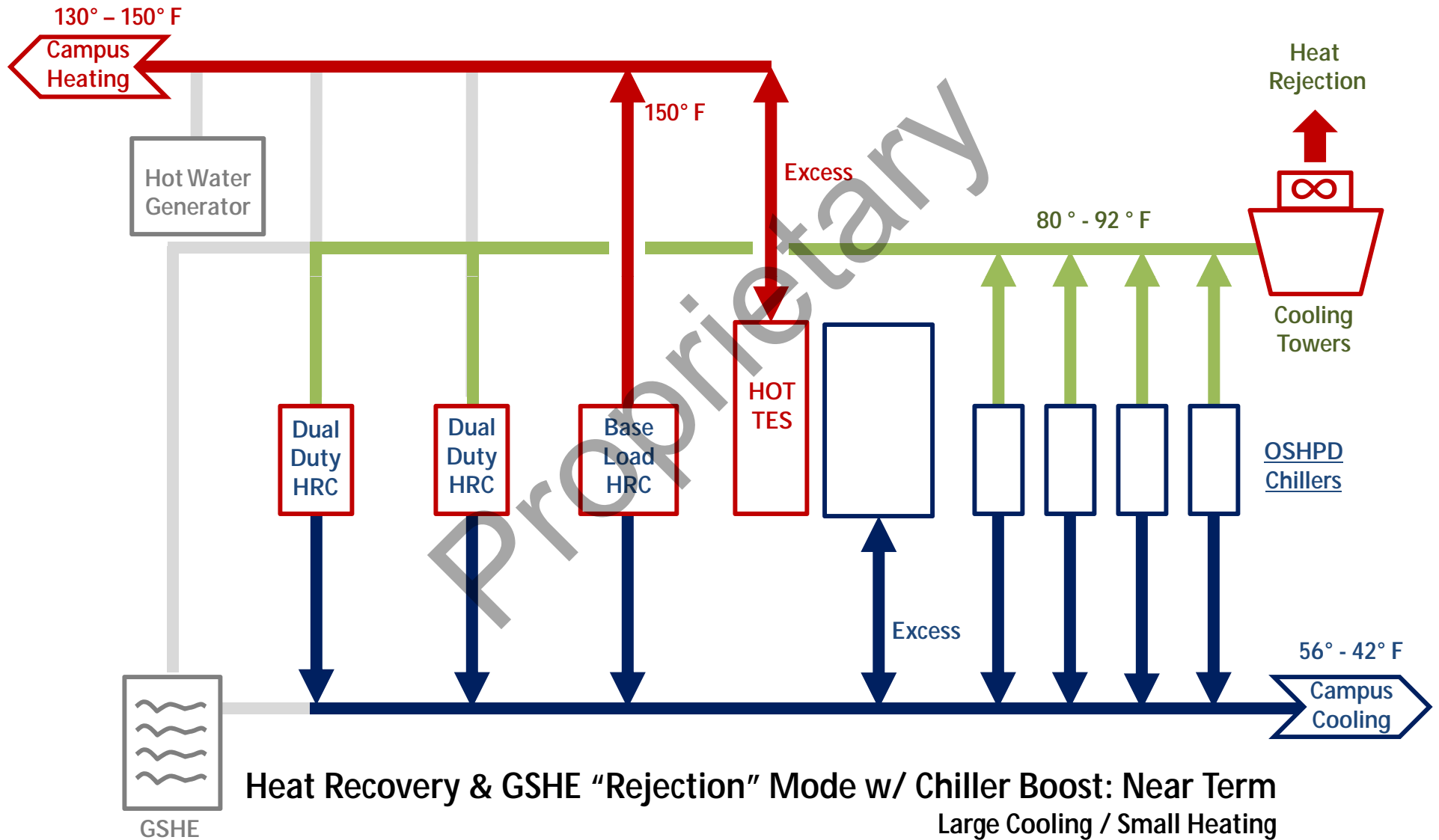

Plant Arrangement / Operation



- Decoupling Generation and Load
- Thermal Battery System

Campus Conversion



Campus Conversion

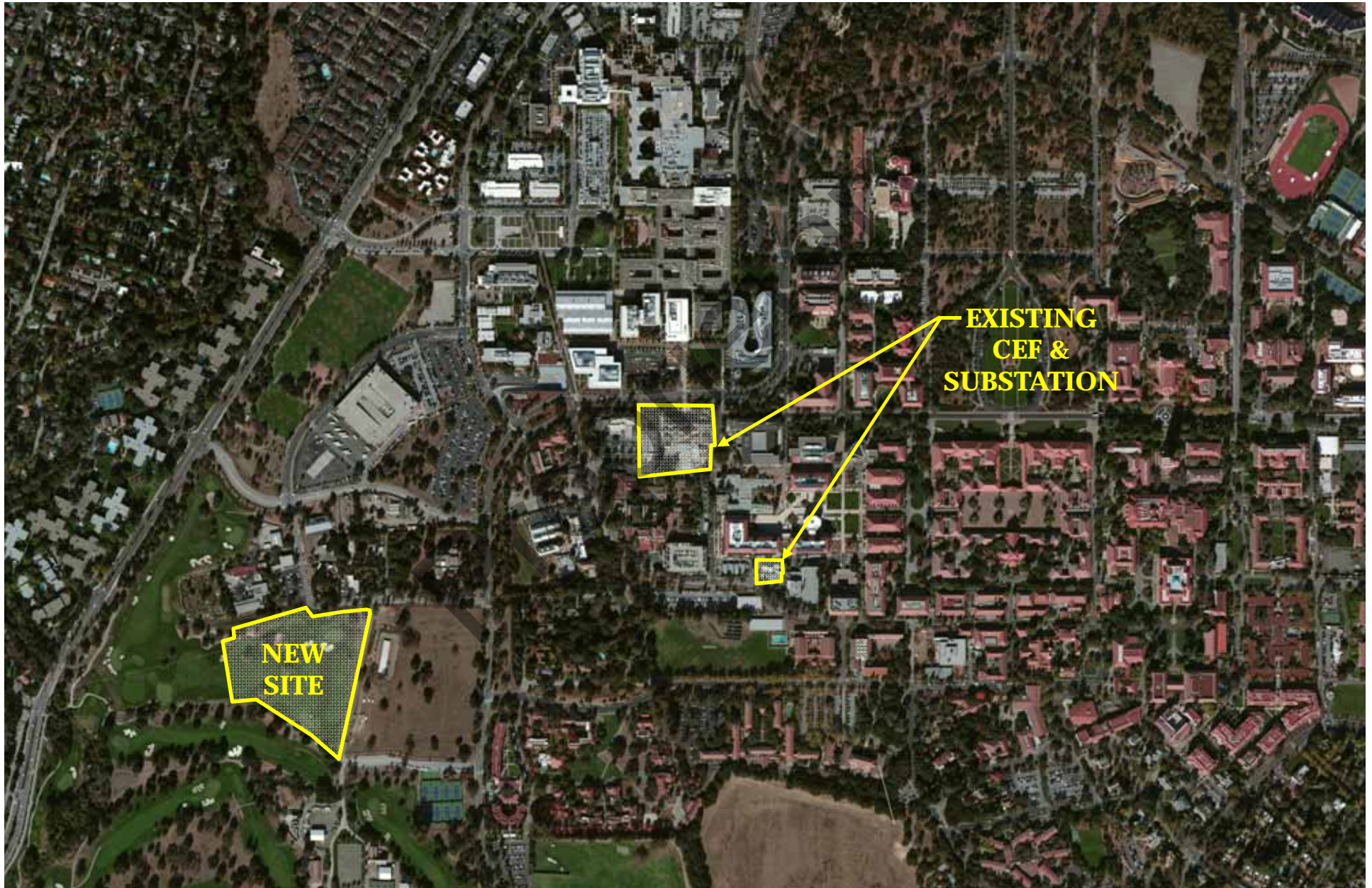

Campus Conversion

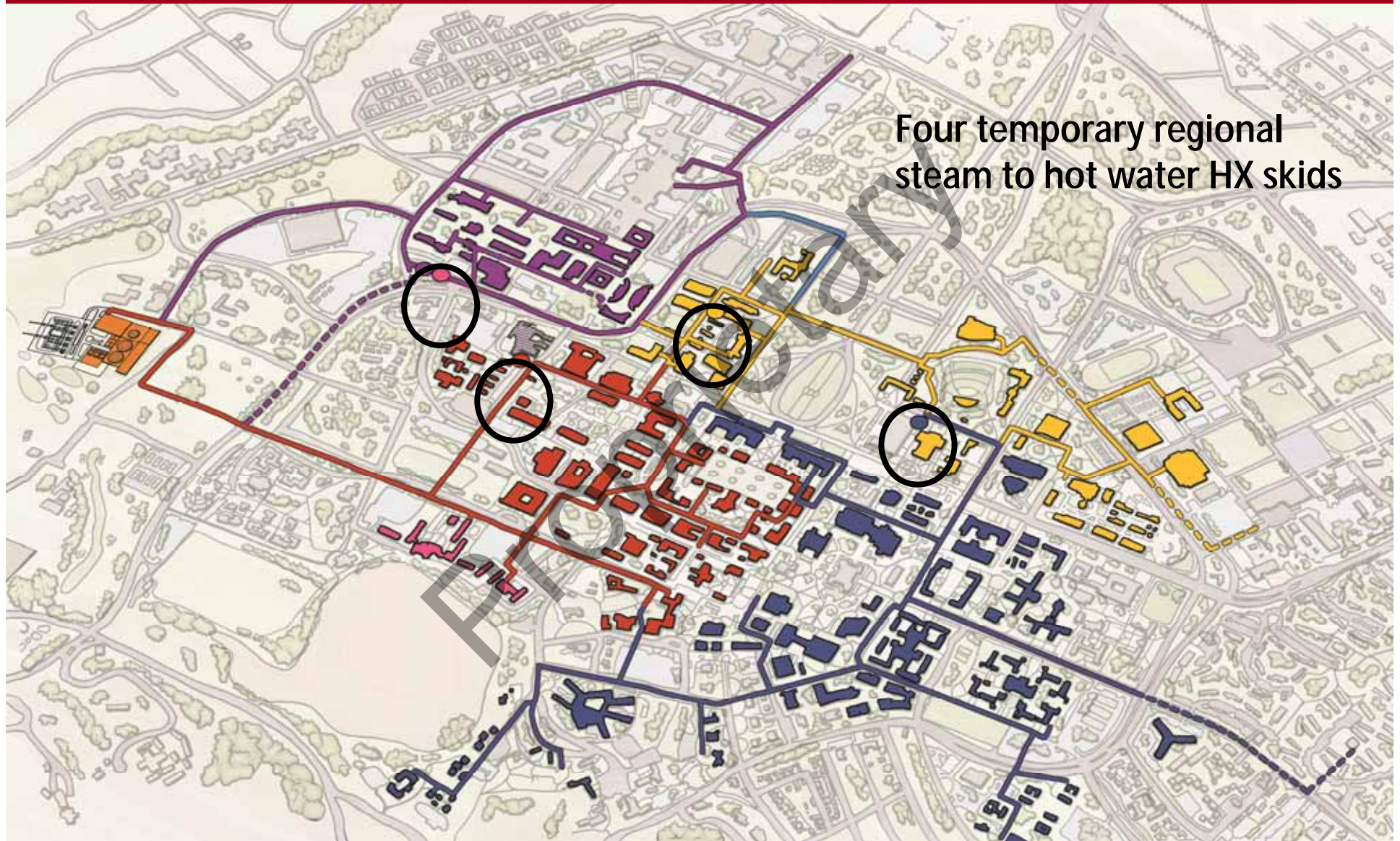

Campus Conversion



- Shallow Bury
- Self-Restrained
- Direct Bury Valves
- Eliminated Vaults
- Chemical Free WT



Campus Conversion

Why Heat Exchangers?

- Isolation of buildings
- High value buildings

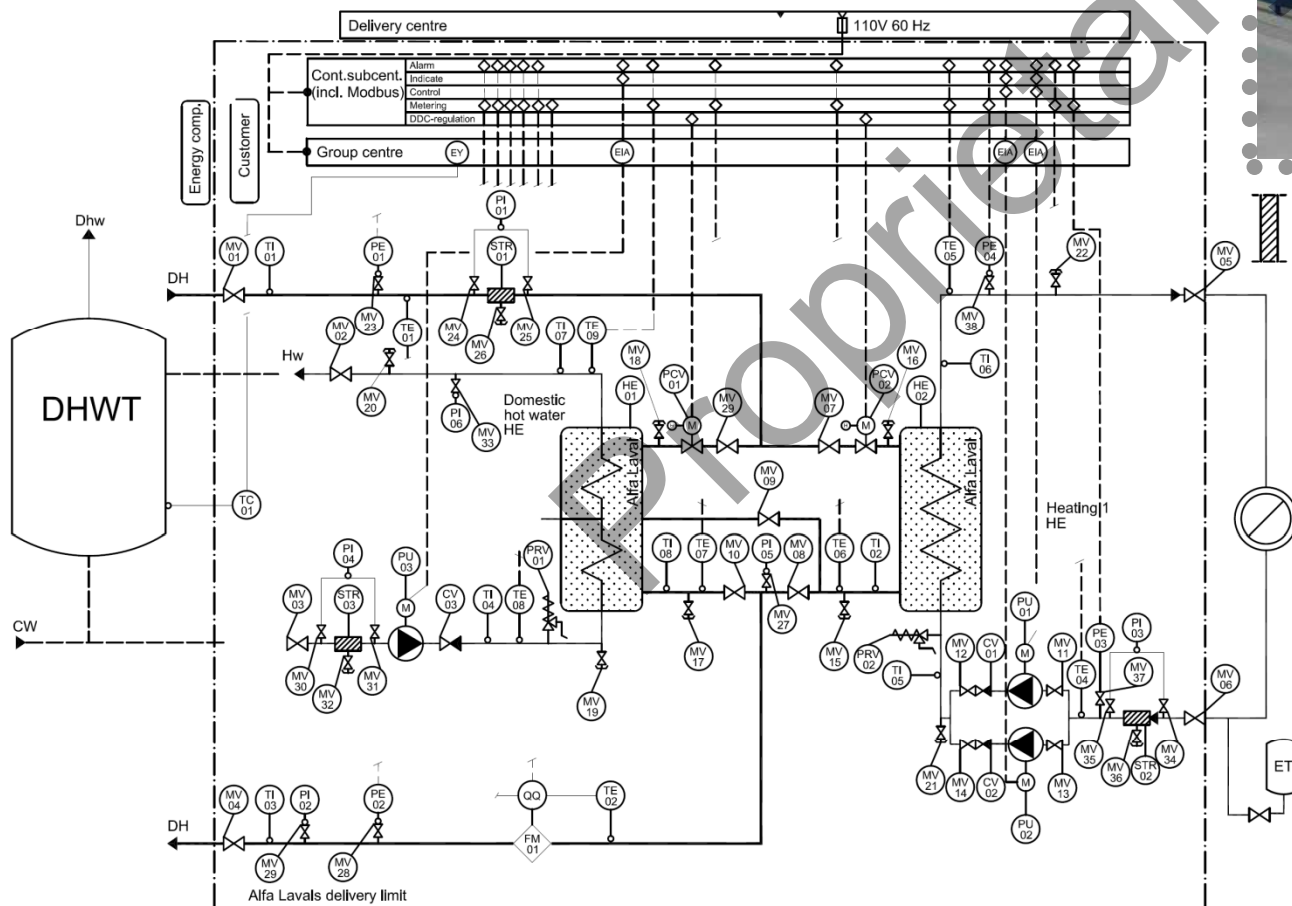

New Electrical Substation

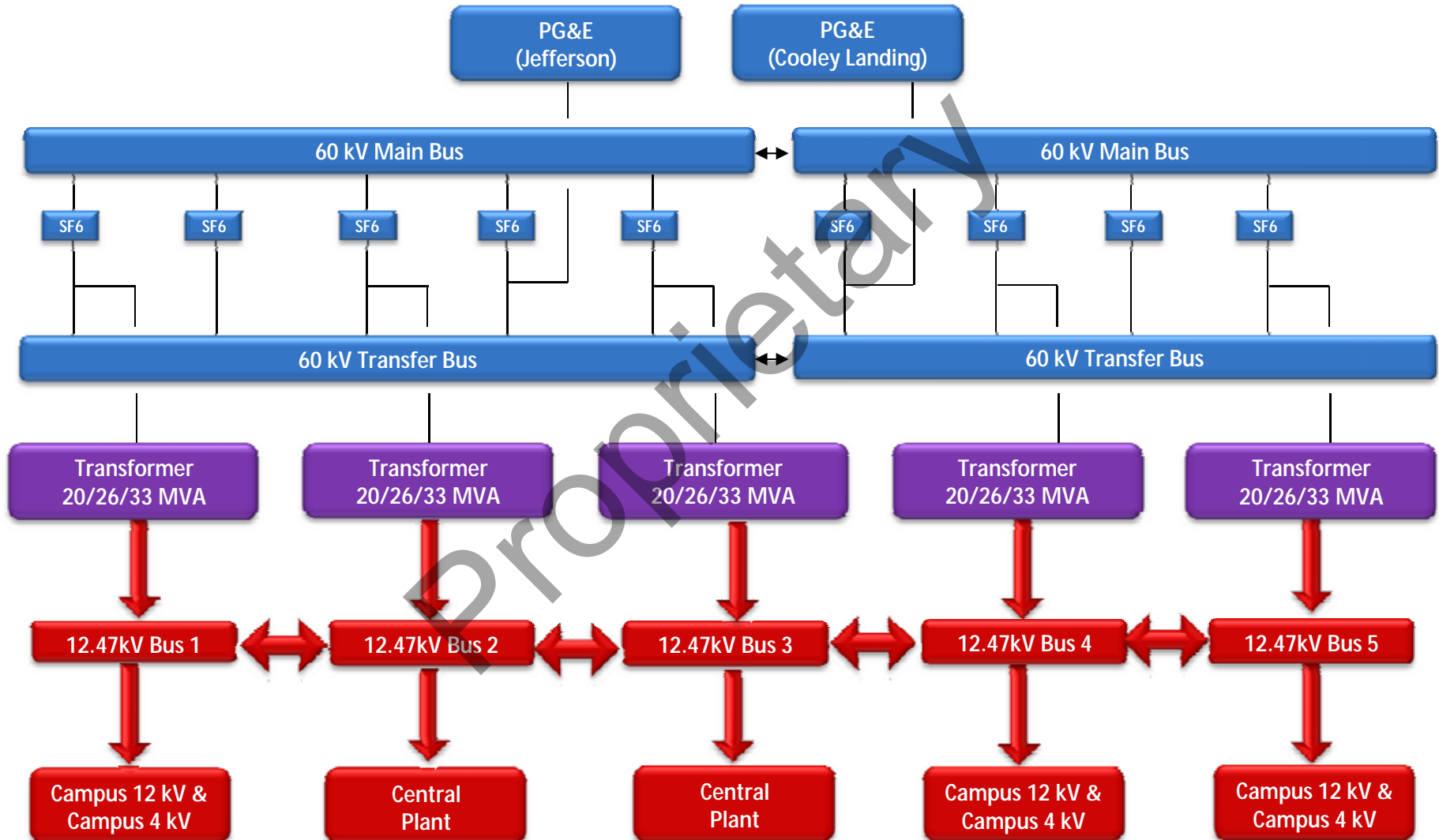

New Electrical Substation

12 kV Switchgear



New Electrical Substation



Replacement Central Energy Facility

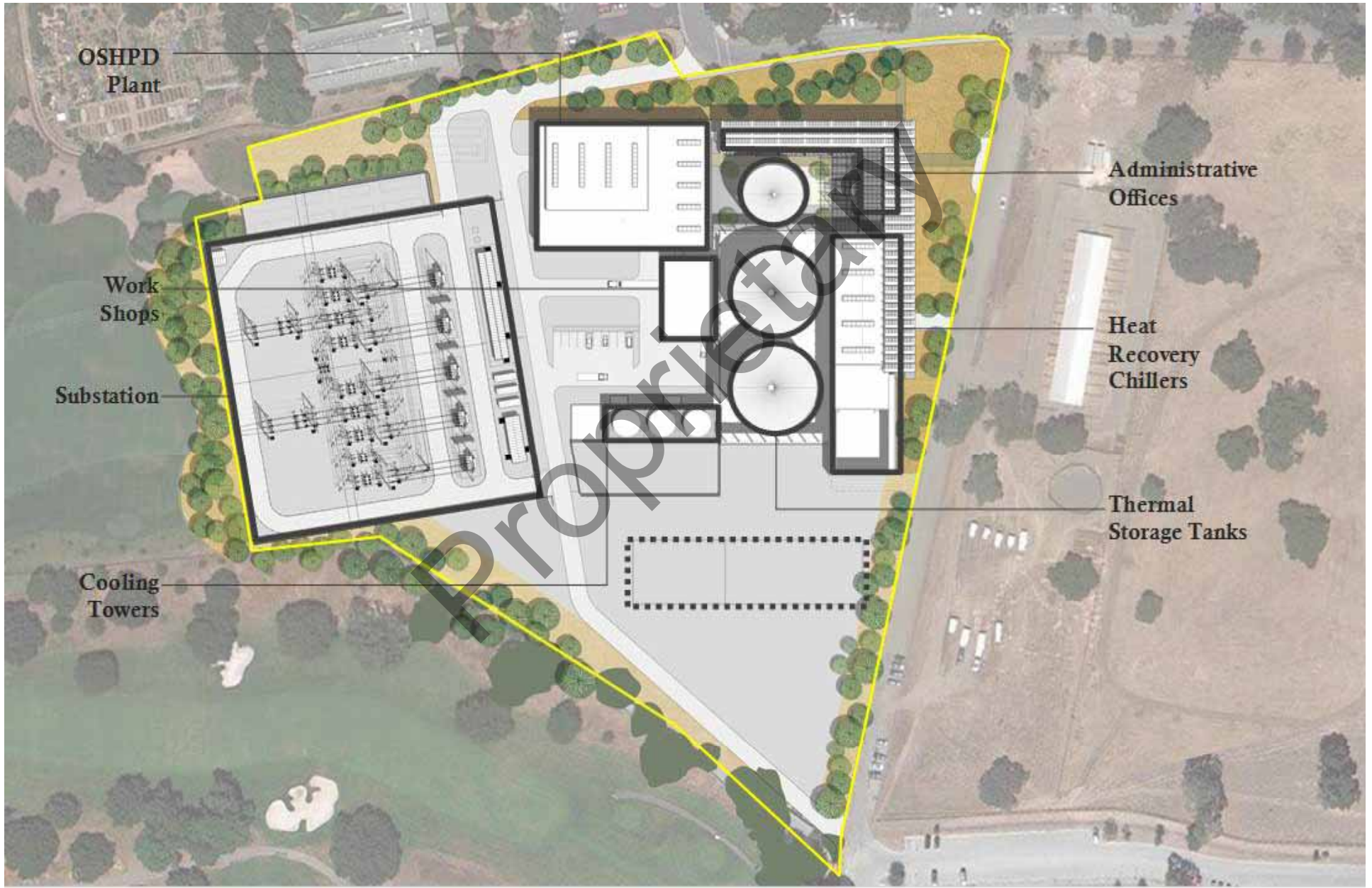

Replacement Central Energy Facility: February, 2013



Replacement Central Energy Facility: October, 2013



Replacement Central Energy Facility: November, 2013



Replacement Central Energy Facility: April, 2014



Replacement Central Energy Facility: July, 2014



Replacement Central Energy Facility: Exterior Rendering



Replacement Central Energy Facility



Replacement Central Energy Facility: Exterior Rendering



Replacement Central Energy Facility



Replacement Central Energy Facility: Design Model

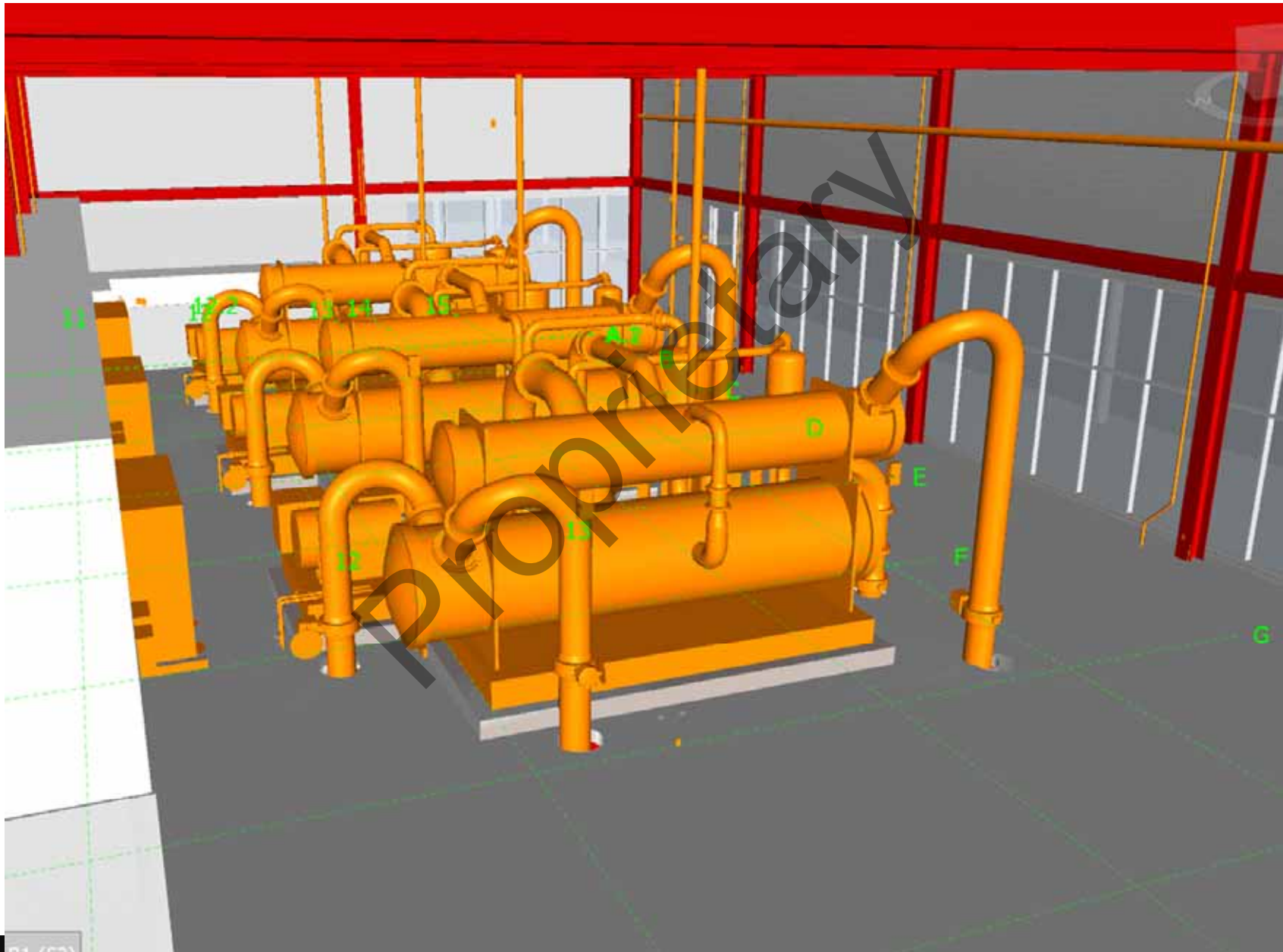

Replacement Central Energy Facility: Contractor Model

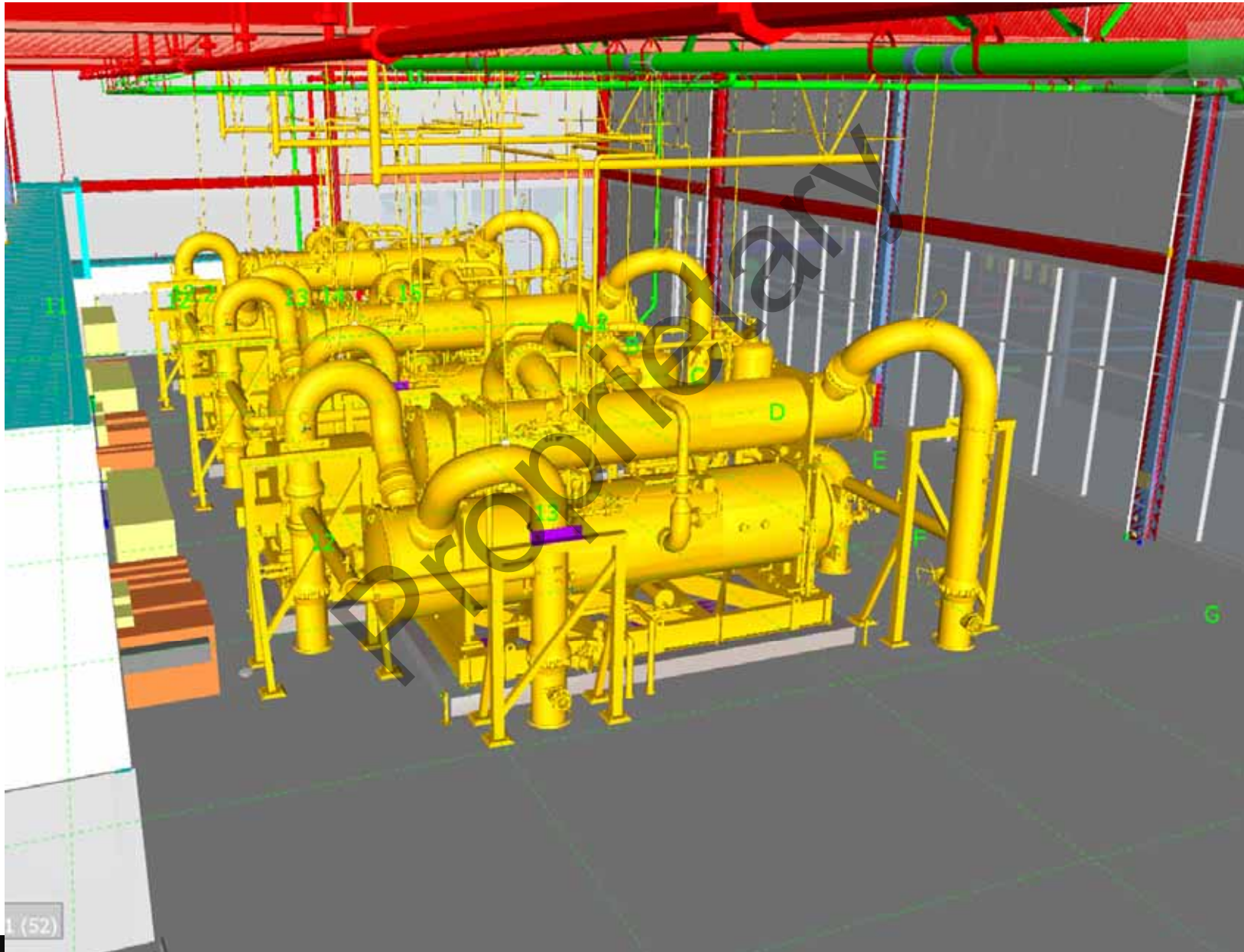

Replacement Central Energy Facility: Progress



Replacement Central Energy Facility: Final Installation



Replacement Central Energy Facility: HRC Rendering



Replacement Central Energy Facility: HRC Installation



Replacement Central Energy Facility: HRC Pump Rendering

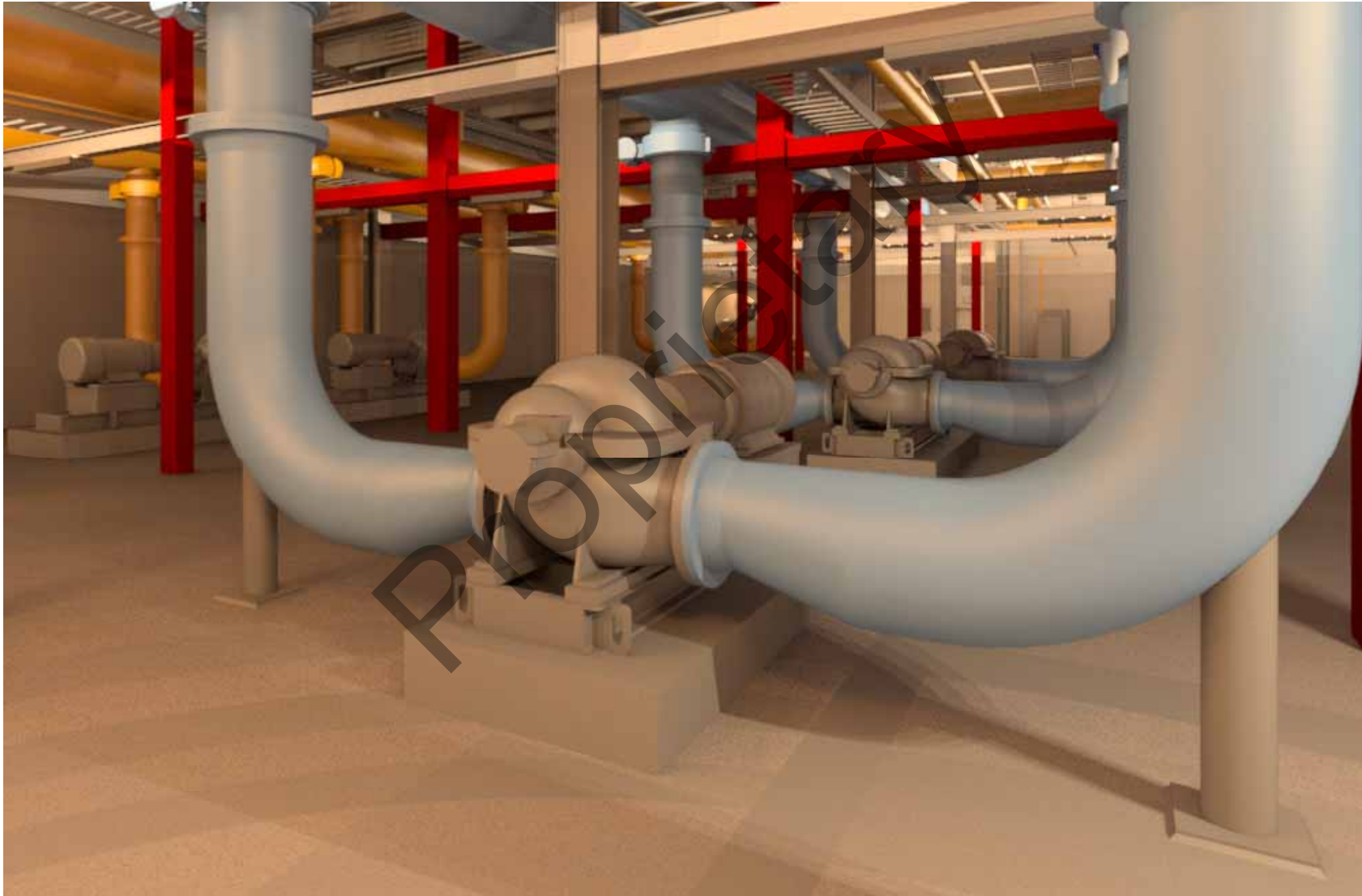

Replacement Central Energy Facility: HRC Pump Installation













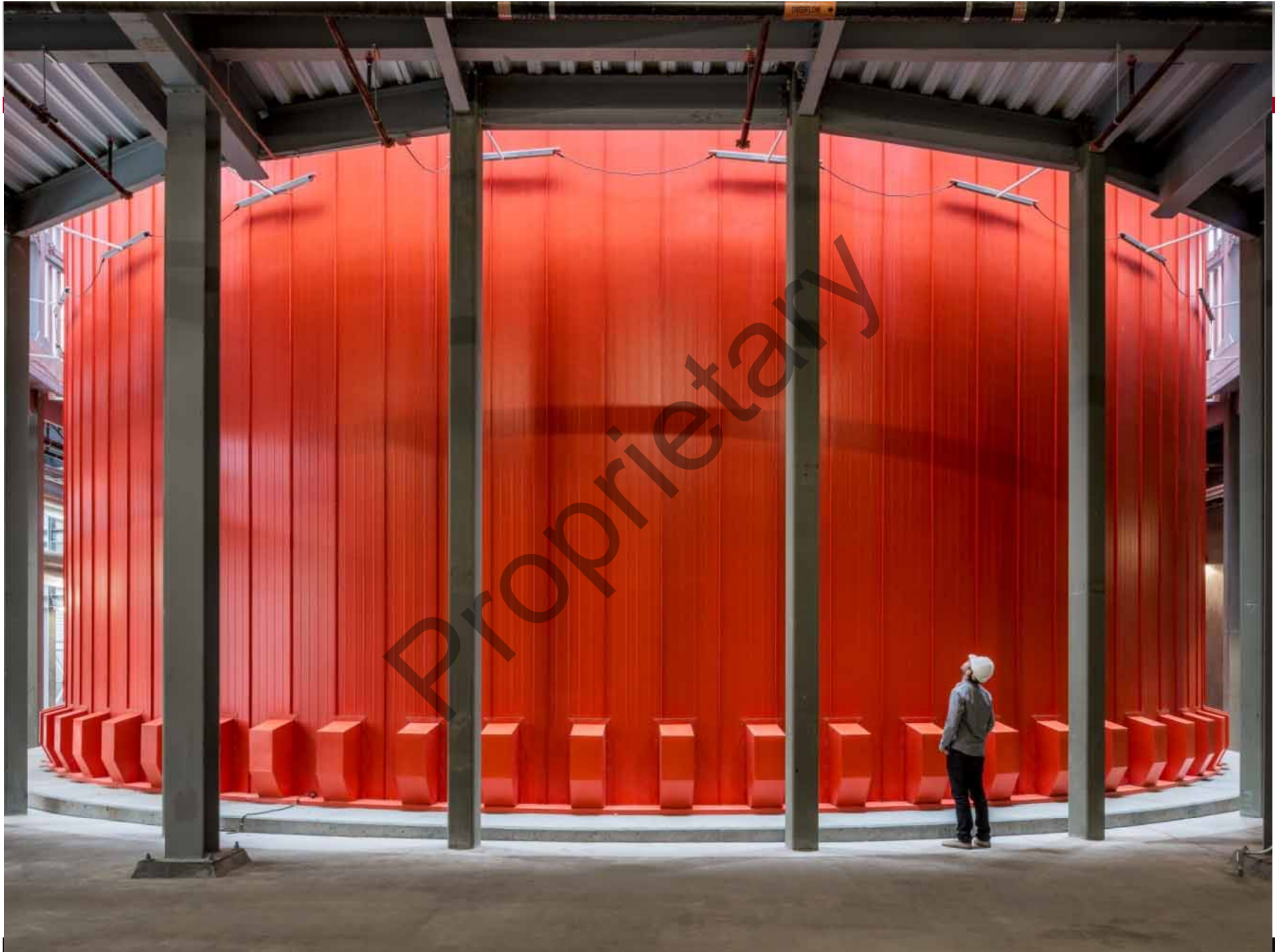

Administrative Wing – NZE Ready

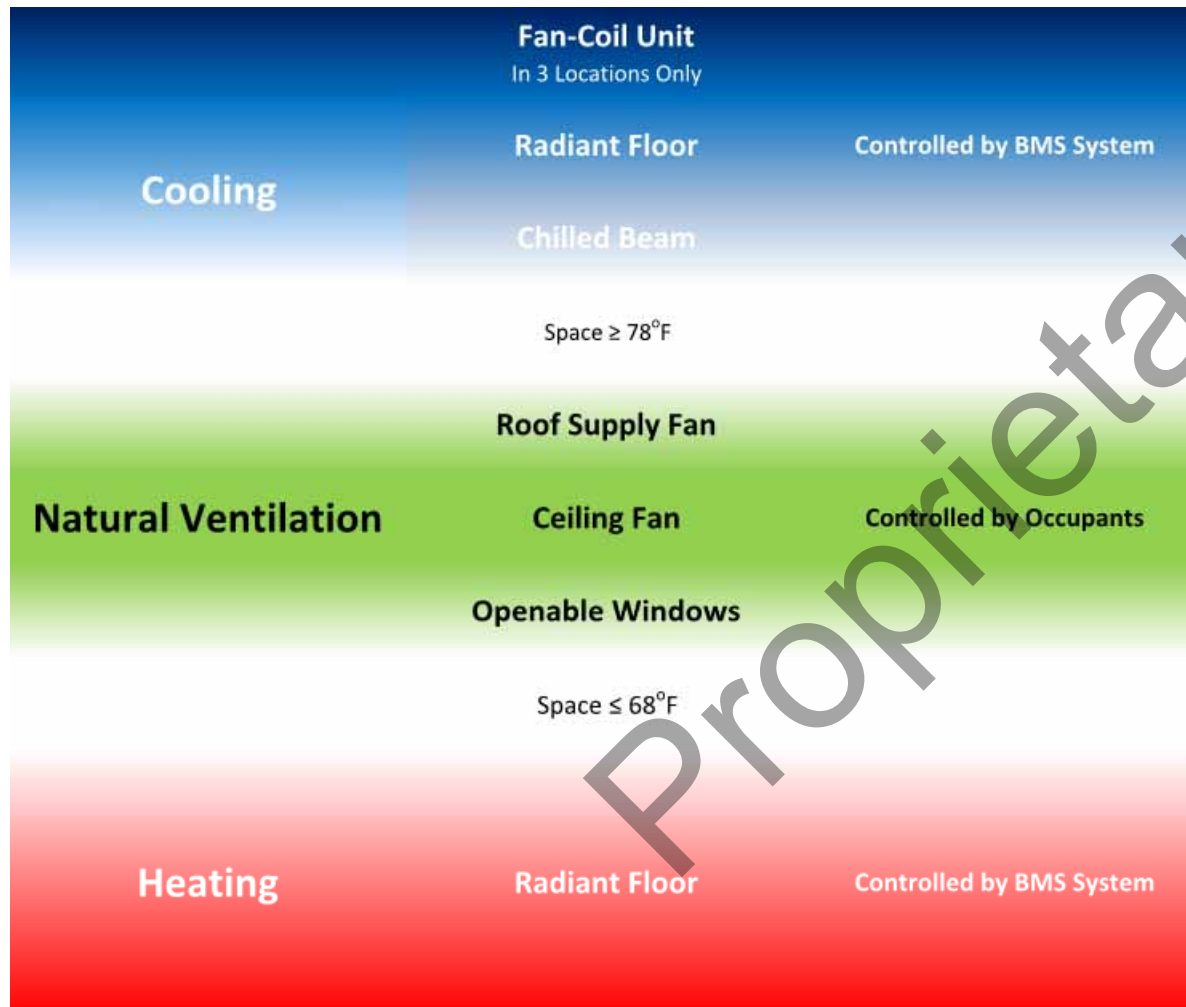

- Natural Ventilation
- Radiant H&C in Slabs
- Chilled Sails
- Phase Change Materials
- Circulating Fans
- Daylighting , LEDs
- PV Systems Integral to Architecture

Administrative Wing







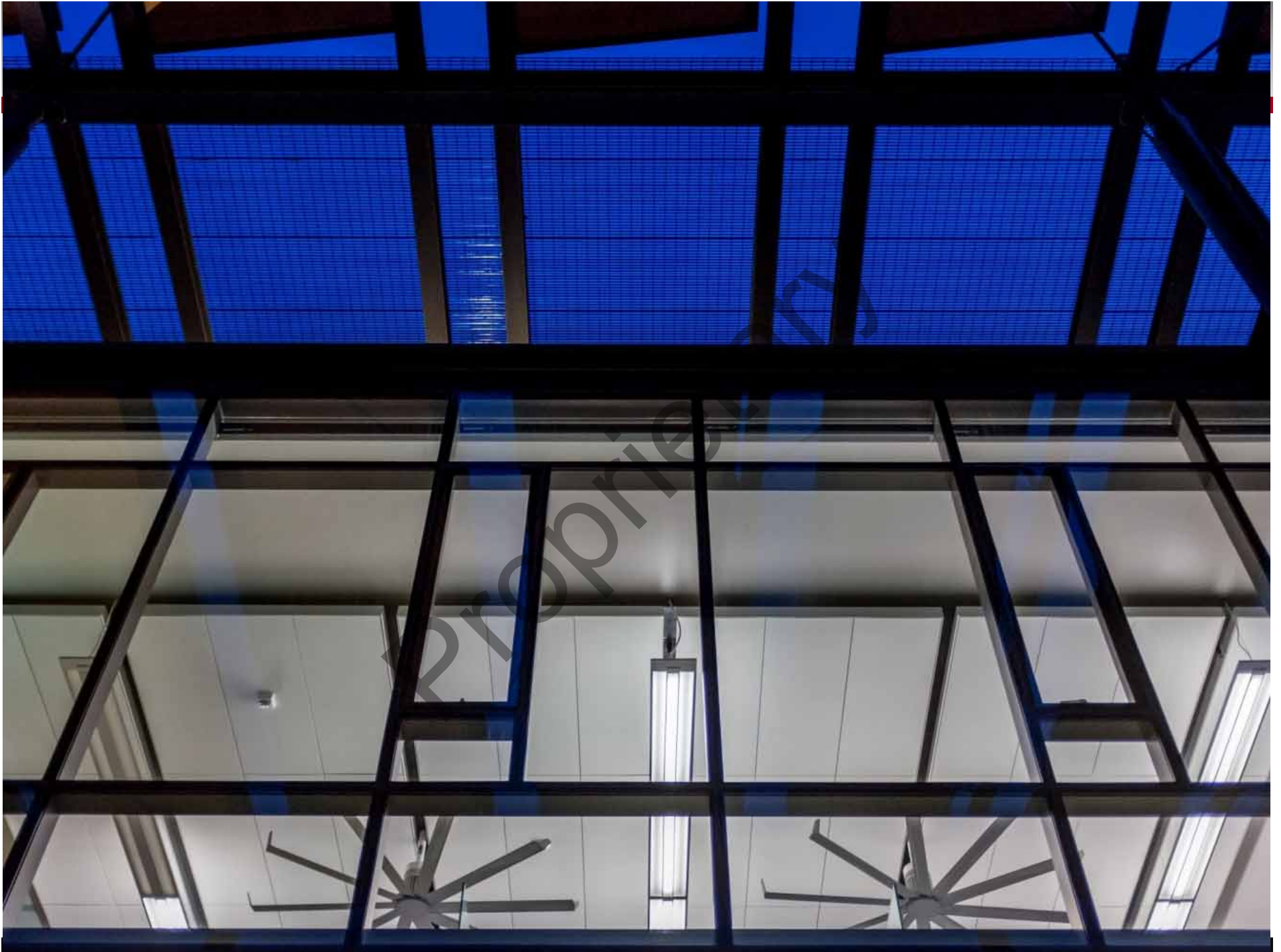

Administrative Wing



Results

- Campus will reduce its carbon emissions, ultimately 50% below 1990 levels by 2050 .
- The new energy system is 70% more efficient than the existing combined heat and power process provided by the current cogeneration plant.
- Potable water use is reduced by 18%.

Results: 50% GHG Reduction

Comprehensive Energy & Climate Plan: Emissions Reduction Wedges & Targets

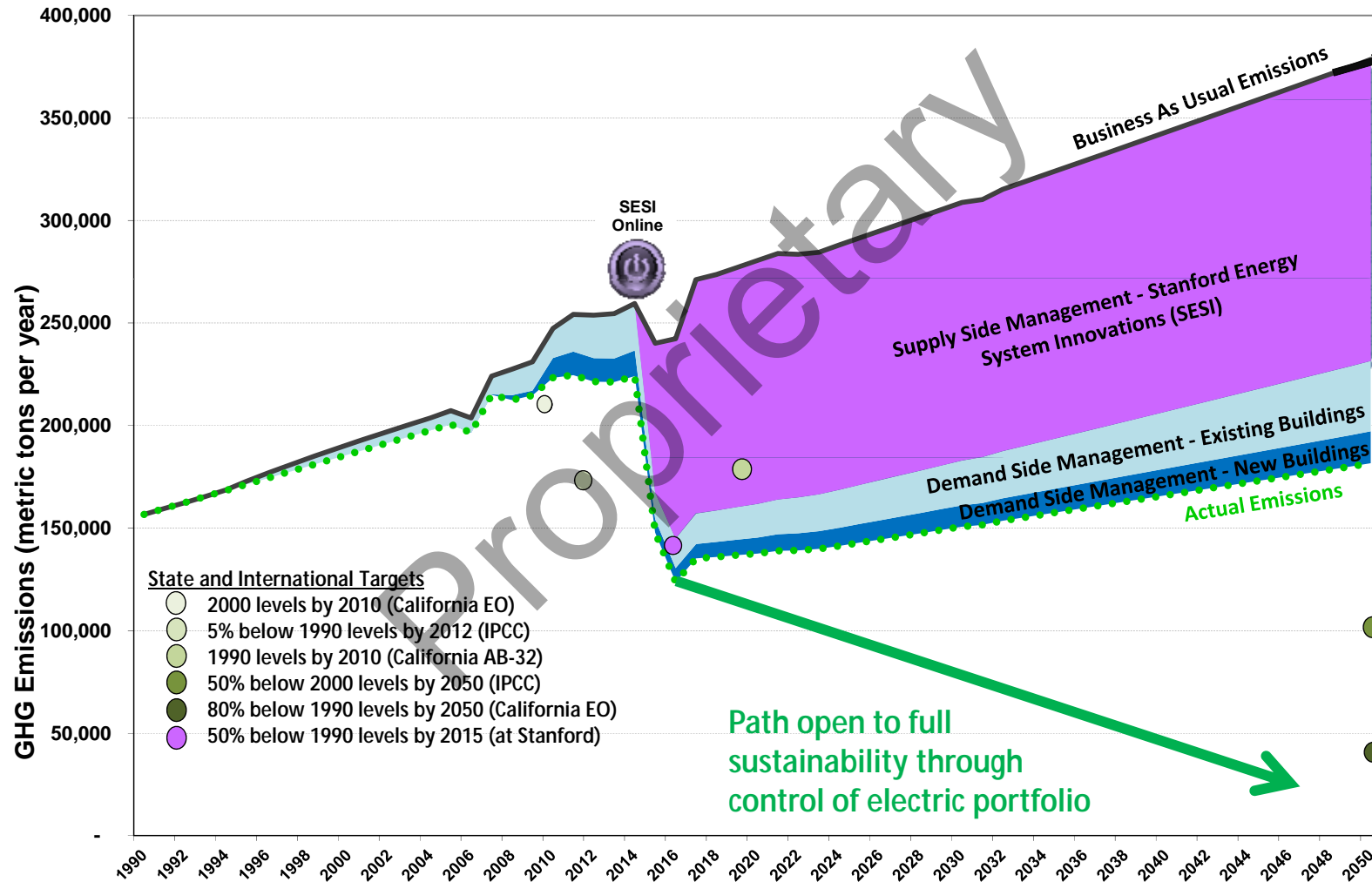

Results: 18% Water Savings (25% with GSHE)

Domestic Water Demand Projections

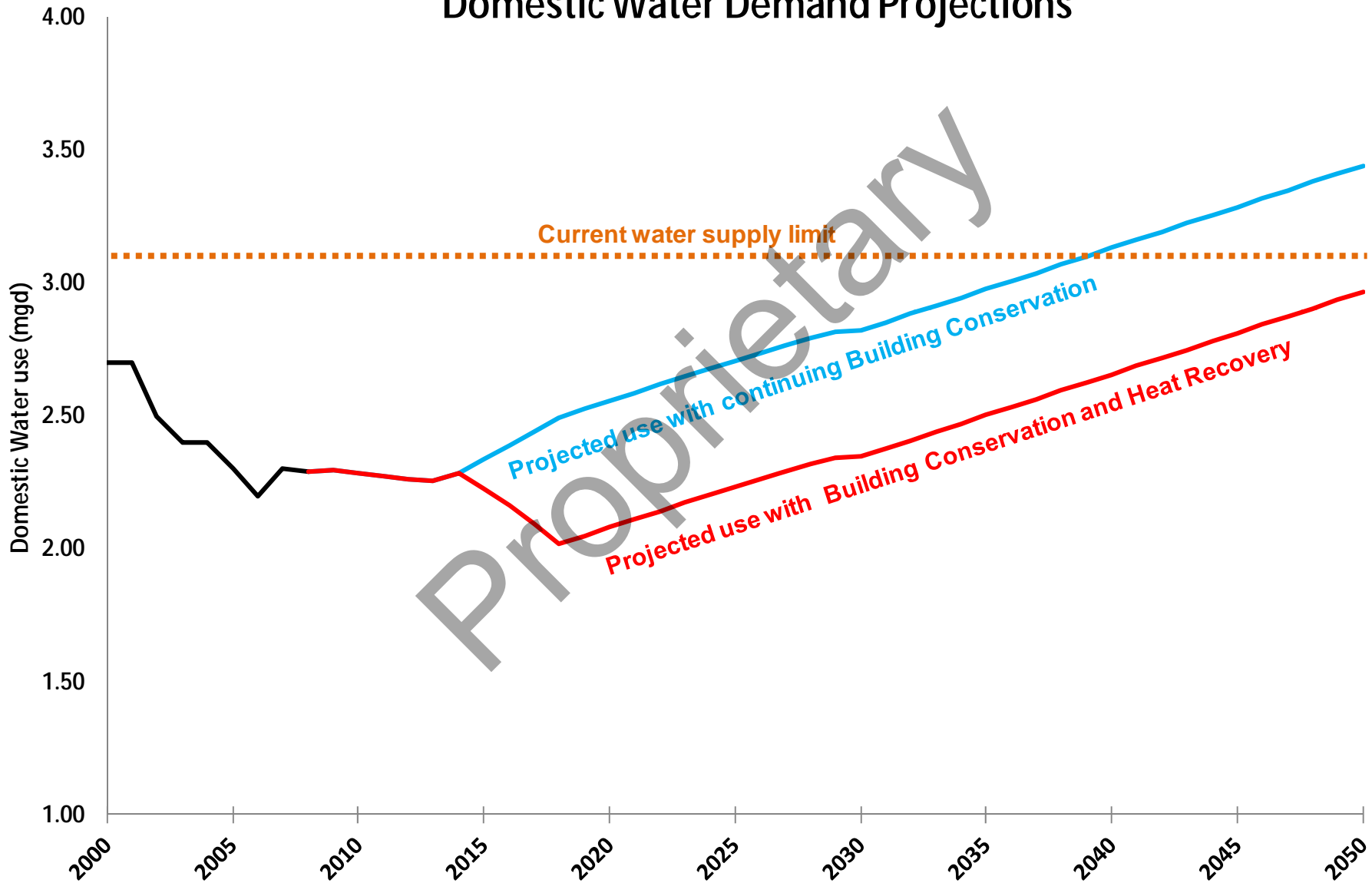

Results: Closing Comments

- Many climates are applicable, not just CA.
- Heating and cooling overlap doesn't need to be instantaneous
- TES decouples the load from the production
- Lower HWS temperature improves efficiency
- Delta T is important for TES, pipe, and pump capacity
- Regional HX's are critical to conversion logistics
- Cooling is just the collection of unwanted heat
- Equipment dispatch is based on load prediction

Colin Moyer

cmoyer@aeieng.com

